

Job No: F25798
 Name: JAS VE
 Address: 30 HANLINGTON ROAD
 30 HANLINGTON ROAD
 Tel: SW10 9JR
 Sheet: 1 of 4

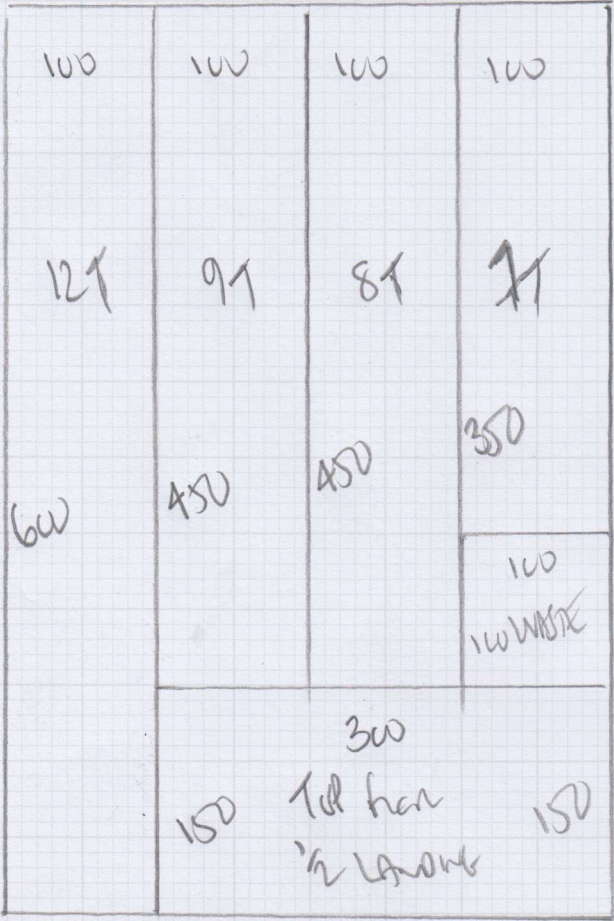

600

CARPET TO SELECT

Row 1 600 x 400
 Row 2 400 x 400
 Row 3 150 x 400
 Total 1750 x 400

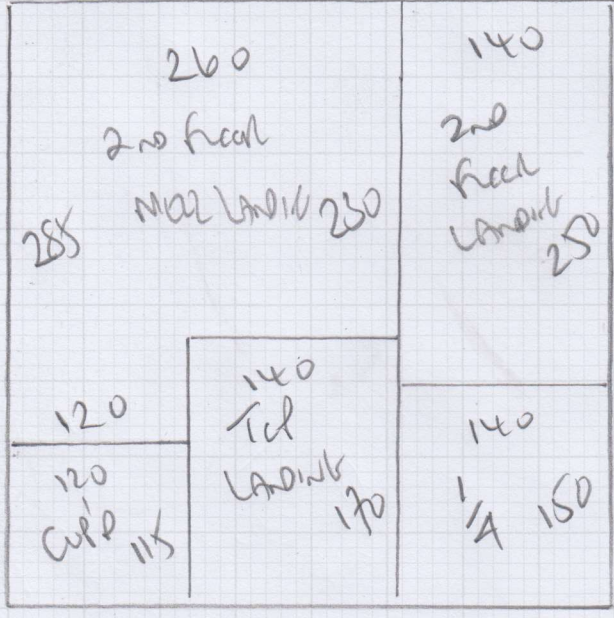

400

70m²

CER MAT NATURAL
 COMMON HALL
 300 x 200

600m²

Job No: F25798
 Name: JOSUE
 Address: 30 HANCOCK TERRACE

Tel: SW10 9JL
 Sheet: 2 of 4

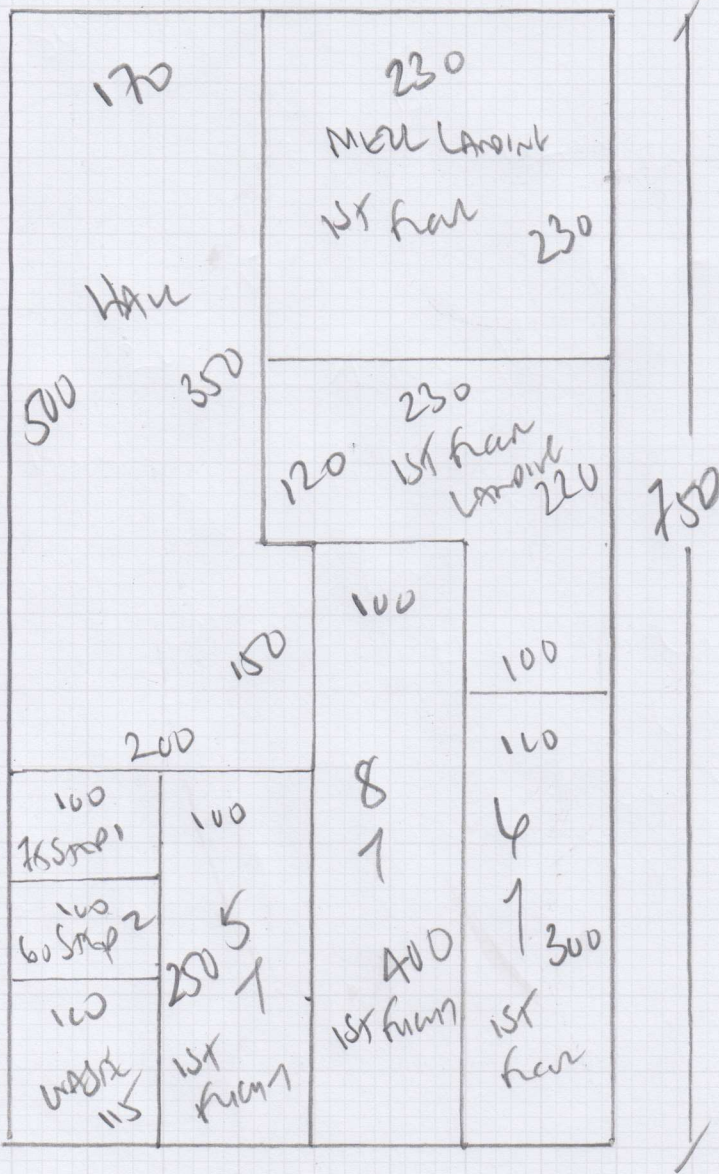

mrcarpet
 Job No: F25798
 Name: JASVE
 Add: 30 HANLCOURT TERRACE LTD
 30 HANLCOURT TERRACE
 Tel: SW10 9JL
 Sheet: 3 of A

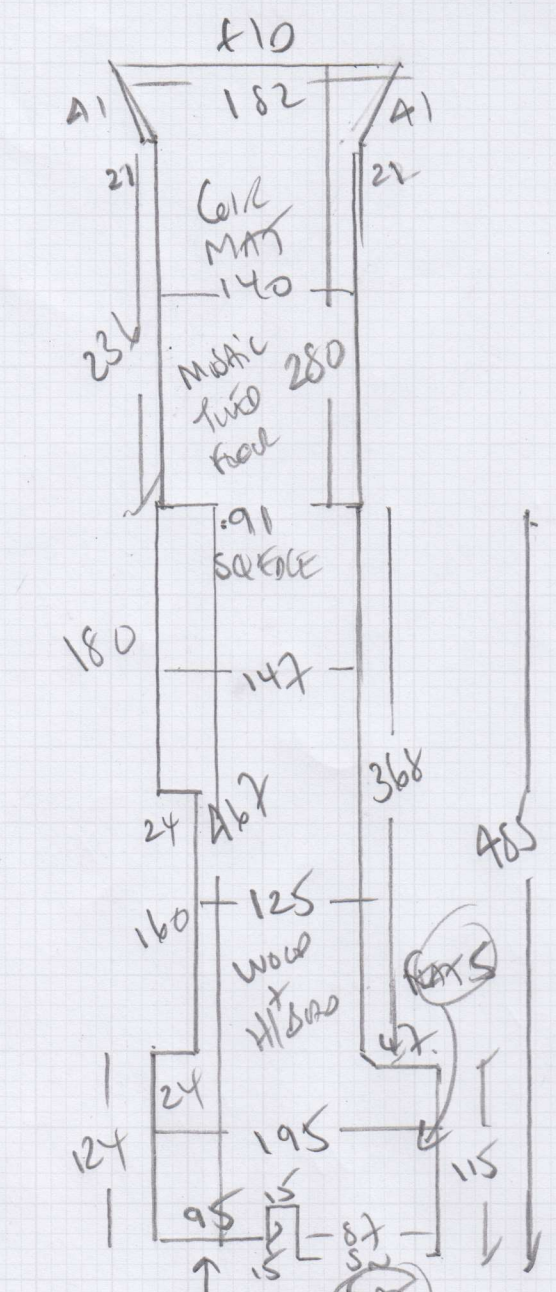

STEP 1 60 x 96
 STEP 2 45 x 96

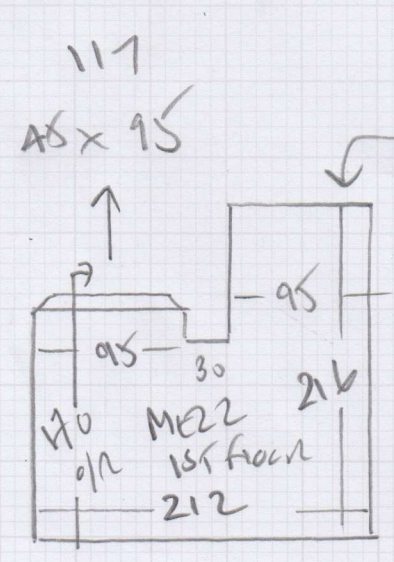
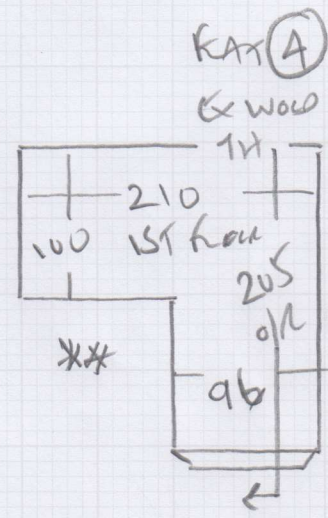

67
 45 x 94

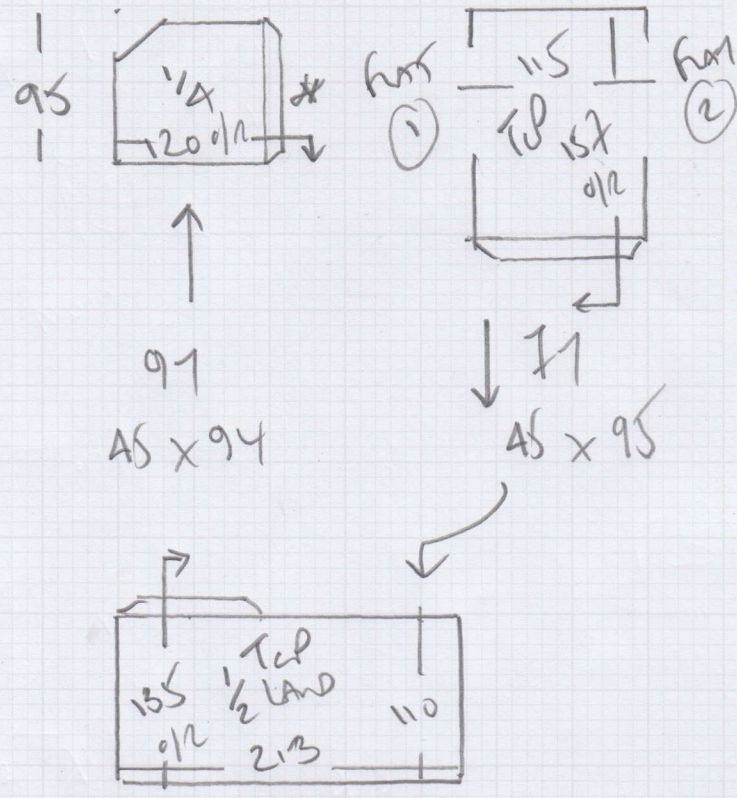

Job No: F25798
 Name: Jasve
 Add: 30 HANCOCK TORRENT QLD
 30 HANCOCK TORRENT
 Tel: SW 70 932
 Sheet: A of A

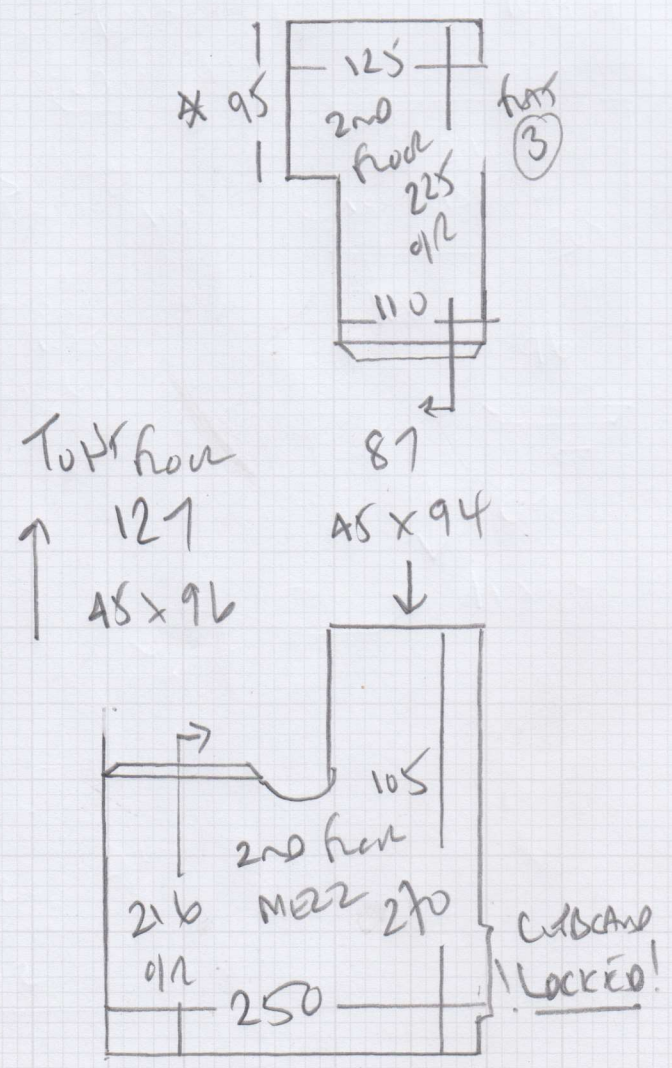

F25798

1st call of 1

Notes for Measure

Estimator: Colin

30 Harcourt Terrace Ltd, 30 Harcourt Terrace

Date of Measure: Thu, 20 Jul 17

At: 9.30

Site Address:

30 Harcourt Terrace

Customer Address:

30 Harcourt Terrace

LONDON

SW10 9JR

LONDON

SW10 9JR

CONTACT: Danny Josue 07944 295127

Mobile	Home	Office
07944-295127		

Email:

dannyjosue@btinternet.com

Areas to be done and Description of Measure

Communal stairs and landings

Instructions and Estimators comments

customer has samples

Not Satisfied yet?
26/7/17

Must Read! 9.30

Office Ref: F25798

30 Harcourt Terrace Ltd, 30 Harcourt Terrace

Date of Measure Thu, 20 Jul 17

At 9.30

Floor: Wood / Concrete / other STONE IS 2 FEET OF STAIR
FROM FAS 4 DOWN

S/edge: Wood/Concrete/No pin/existing (if existing, allow ___ sticks to supplement where necessary)

Sticking Req'd: Yes/ No Type: Fastset / Other SPAWN
COIL MAX TO ENTRANCE LANDINGS ARE WOOD +
H/BOARD DOWN

Underlay: Re-use Existing / New required

Type: 42oz Felt / Fomalux / PU Foam / Luxury PU Foam / LowTog / Durafit

Doorbars: Alloy / Satin Ali / Polished Ali / Anod / Solid Brass / Chrome / Nisheen
Seam/Wood/T/Holds: colour _____

Door Clearance: OK / Low (advise on quote)

Uplift: No / Yes (if "Yes" - what type?) INSTR ON AD TERN + STAIR

Furniture: No / Yes (if YES, please specify the following) - 1 man / 2 men (Fitter to get paid) £ _____ total/per room

Parking Cost: Free / £ 360 per hour

Parking Restrictions: (type) / £ PFD - 150 HANDS AWAY IF LUCKY !!

Congestion Zone: No / Yes

Access: Easy / Hard / 2 men req'd / GOOD - 3RD floor?

Runners: ~~Whipping~~ / Binding (if binding, specify type)

Tape size: ~~1 1/2"~~ / 2" / 3" / 5"

Style: ~~Top~~ taping / Side binding

Stairrods: Type _____ Nr _____ Size _____

Must Read: 9.30