

P27051

2nd call of 3

Notes for Measure

Estimator: Colin

Mrs P H Harries, 66 Melrose Road

Date of Measure: Thu, 5 May 16

At: 11am - 12pm

Site Address:
66 Melrose Road

Customer Address:
66 Melrose Road

LONDON

SW18 1PG

LONDON

SW18 1PG

CONTACT:

As customer details

Mobile

Home

Office

020-8877-0255

Email:

No email

Areas to be done and Description of Measure

Kitchen for Halls Forest Felt - 1740 Timber Natural @ £20m². CHECK CONDITION OF EX CERAMIC TILES & ADVISE IF WE CAN LAY OVER?

Instructions and Estimators comments

New kitchen units to be installed (cust. has a plan). Advised that we might need to prime & screed?

KICKSCANS - ADVISE CHANGE BY KITCHEN FITTER
+ 3 x Dials to EDGE

Must Read!

Customer will be at home

Office Ref: P27051

Mrs P H Harries, 66 Melrose Road

Date of Measure Thu, 5 May 16

At 11am - 12pm

Floor: Wood / Concrete / other COLAMICS

S/edge: Wood/Concrete/No pin/existing (if existing, allow ___ sticks to supplement where necessary)

Sticking Req'd: Yes/No Type: Fastset/Other

Underlay: Re-use Existing / New required REMOVE + SCREWS REINSTALLED

Type: ~~42oz Felt~~ / Fomalux / PU Foam / Luxury PU Foam / LowTog / Durafit

Doorbars: Alloy / Satin Ali / Polished Ali / Anod / Solid Brass / Chrome / Nisheen Seam/Wood/T/Holds: colour REDUCING STAIR

Door Clearance: OK / Low (advise on quote) ENTRANCE TO KITCHEN 12 x 615mm
DEADEND TO UTILITIES

Uplift: No / Yes (if "Yes" - what type?) _____

Furniture: No/Yes (if YES, please specify the following) - 1 man / 2 men (Fitter to get paid) £_____ total/per room

Parking Cost: Free / £ 250 per hour

Parking Restrictions: (type) / £ PROVIDE ACCESS ON FREE ON DRIVEWAY
WITH PERMISSION FROM CUSTOMER

Congestion Zone: No Yes

Access: Easy / Hard / 2 men req'd / Ground floor?

Runners: Whipping / Binding (if binding, specify type)

Tape size: 1 1/2" / 2" / 3" / 5"

Style: Top taping / Side binding

Stairrods: Type _____ Nr _____ Size _____

Must Read: Customer will be at home

Office Ref: P27051

Job No: P 27051
Name: HARRIES
Address: 66 MELROSE ROAD
SW 18 PG
Tel: _____
Sheet: _____ of: _____

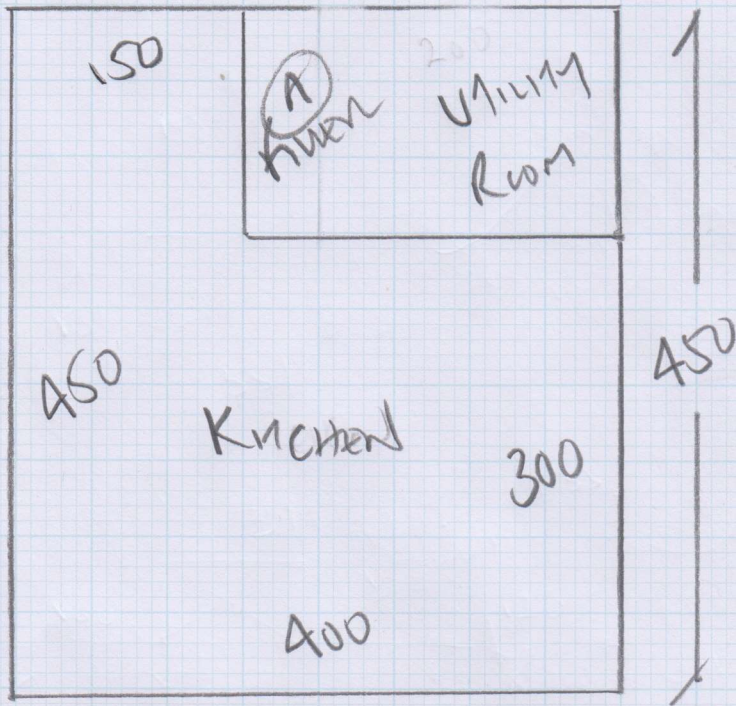

Haus Vinyl
Forest FELT
1740 TIMBERNAUEN

450 x 400

18m²

Job No: P27057
 Name: HARRIES
 Address: 66 MERLASE ROAD
 SW18 1PG

Tel: _____
 Sheet: _____ of: _____

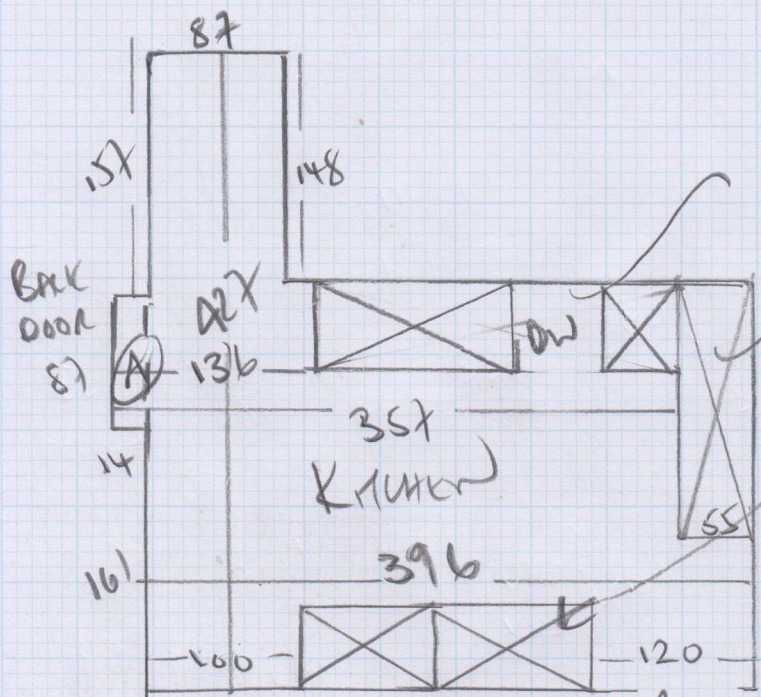

NEW KITCHEN UNITS
 NOT IN YET!!

RESOLVING STRIP REQUIRED
 760mm
 TO PARQUET FLOORING IN HALL
 CURRENTLY FINISH WITH CERAMIC TILES
 IN KITCHEN

APPROX 10mm HEIGHT DIFFERENCE BETWEEN UTILITY CUBOARD
 FLOOR + KITCHEN FLOOR (SEE PHOTO SENT TO PETER'S BROTHER)
 THE UTILITY ROOM IS 10mm HIGHER THAN KITCHEN

