

mrcarpet
 Job No: P28172
 Name: Gordon
 Address: 7090 Lincolnham Rd
 SWIS 18H
 Tel:
 Sheet: of:

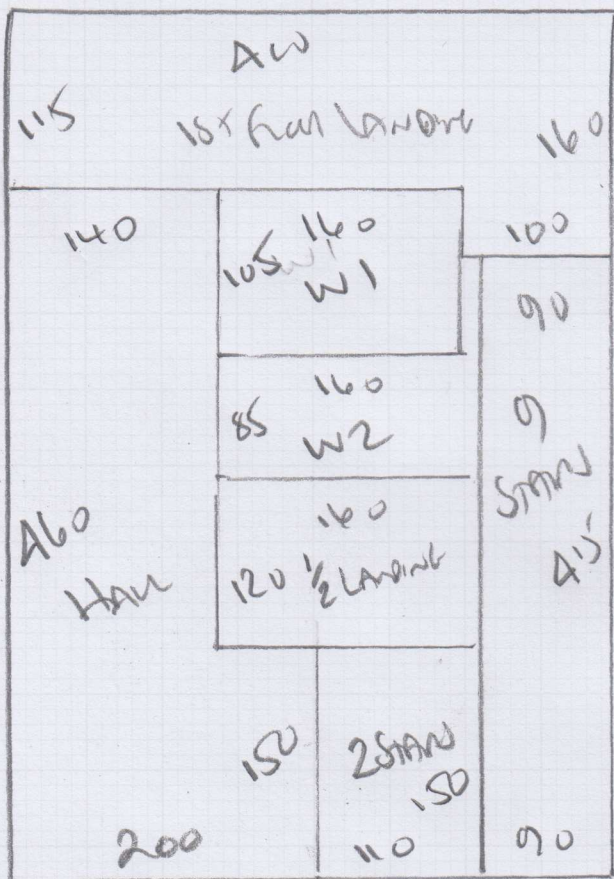

575

AUBORAN
 Colour AUB-024

Plan 575 x 400
 23m²

front Bedroom
 540 x 500
 27m²

Job No: P28172
 Name: Gordon
 Address: 79 ERLINGTON RD
 SWIS 1BH
 Tel: _____
 Sheet: _____ of _____

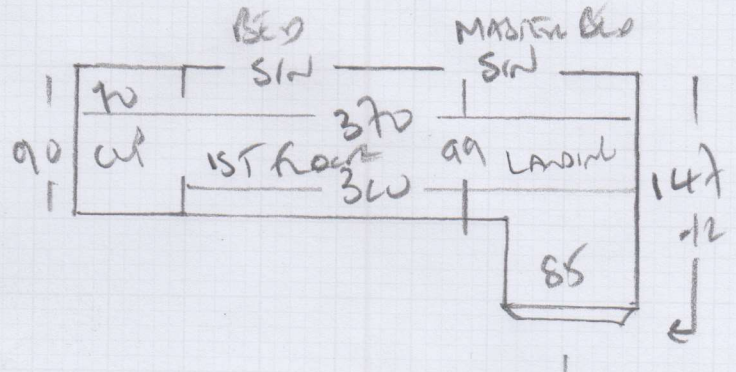
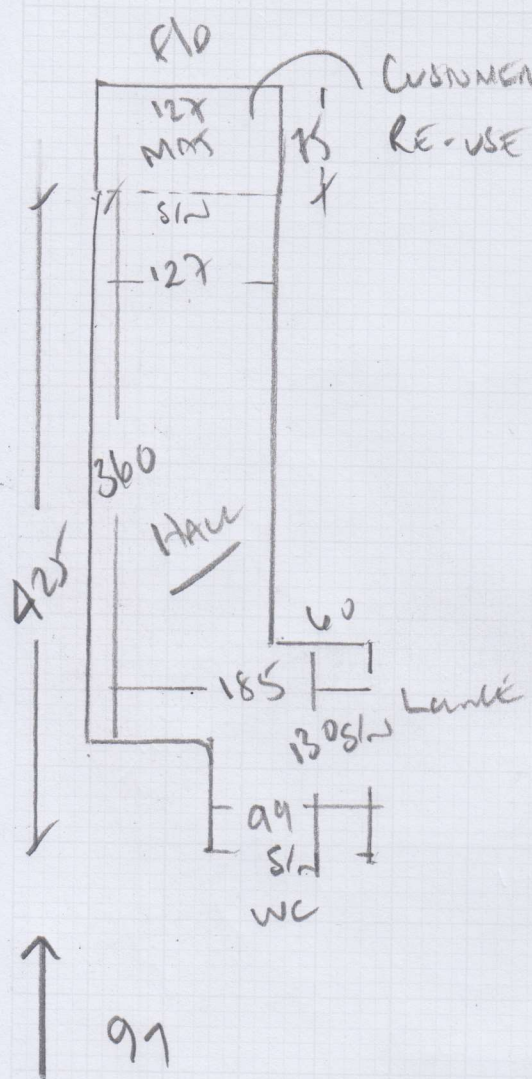

27
 45 x 81

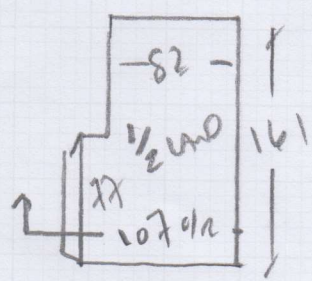

99
 45 x 81
 W1 96 x 80
 1/2
 W2 80 x 112

WOOD/ENGINEERED BEAMS

UPRIFT RUNNERS ON PU FRAM + METAL ANGLE EDGE ON NOSING OF AN STAIRS + LANDINGS

SKIRTING ON TOP OF WOOD - (NO SCOTIA BEADING)

DOORS - NEED CASING OFF 1ST FROM LANDING (x3)

BUT CUSTOMER REQUESTED TO FIT S/MATS OUTSIDE OF BEDROOM DOORS TO AVOID COST OF CUTTING DOORS

CULDEBARD DOOR NEEDS CASING REGARDLESS

Job No: P2872
Name: Gordon
Address: 79 Enlwyntan
Swis
Tel:
Sheet: of:

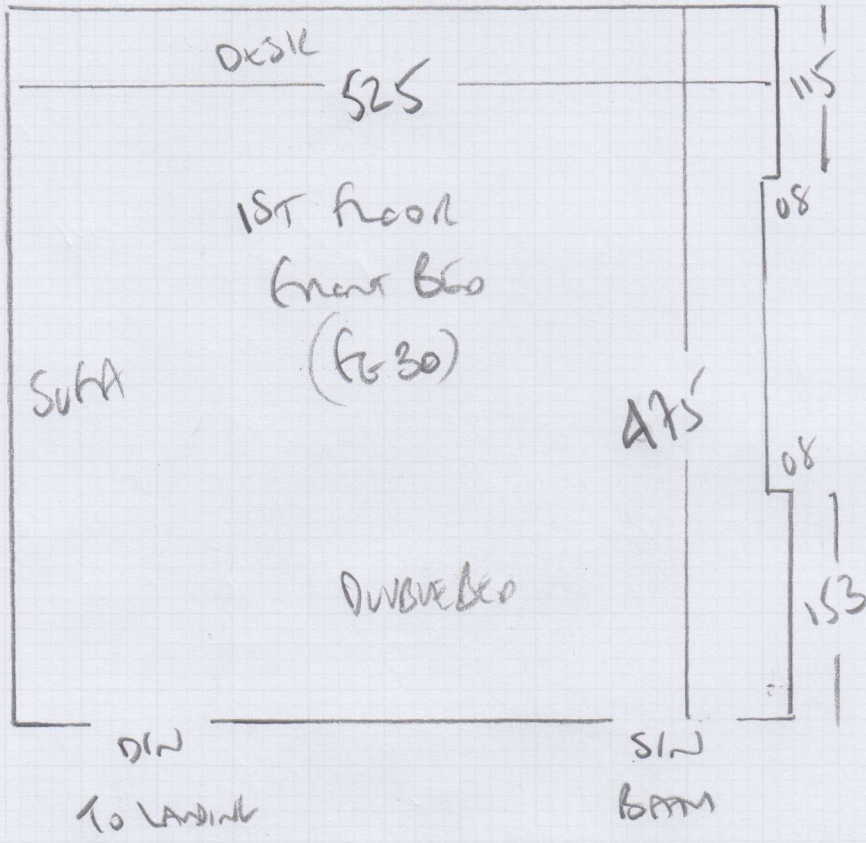

ALBURN
Corner AB-024
540 x 520

27m²

* Doors need casing ← NO clearance at bustout (2mm max)

P28172

2nd call of 2

Notes for Measure

Estimator: Colin

Mrs Gordon, 79 Erpingham Road

Date of Measure: Tue, 6 Feb 18

At: 11:00-12:00pm

Site Address:
79 Erpingham Road

Customer Address:
79 Erpingham Road

LONDON SW15 1BH

LONDON SW15 1BH

CONTACT: As customer details

Mobile	Home	Office
07785-247869	020-8785-3158	

Email:
annsofiegon2@gmail.com

Areas to be done and Description of Measure

Hall, Stairs & Landing for Alboran - ALB-024 @ £25.50 less 25%

Instructions and Estimators comments

Quote for 42oz Felt as customer will be selling property

Must Read! **Meet customer on site**

Office Ref: P28172

Mrs Gordon, 79 Erpingham Road

Date of Measure Tue, 6 Feb 18

At 11:00-12:00pm

Floor: Wood / Concrete / other _____

S/edge: Wood / Concrete / No pin / existing (if existing, allow ___ sticks to supplement where necessary)

Sticking Req'd: Yes / No Type: Fastset / Other

Underlay: Re-use Existing / New required

Type: 42oz Felt / Fomalux / PU Foam / Luxury PU Foam / LowTog / Durafit

Doorbars: Alloy / Satin Ali / Polished Ali / Anod / Solid Brass / Chrome / Nisheen
 Seam/Wood/T/Holds: colour _____

Door Clearance: OK / Low (advise on quote) *CUSTOMER DOESN'T WANT TO PAY FOR DOOR LEASING!! FIT SIGNALS OUTSIDE*

Uplift: No / Yes (if "Yes" - what type?) *RUNNERS ON STAIRS DOWNWARDS*
WHIPPED RAILS ON HALL + LANDING

Furniture: No / Yes (if YES, please specify the following) - 1 man / 2 men (Fitter to get paid) £ _____ total/per room

Parking Cost: Free / £ 260 per hour

Parking Restrictions: (type) / £ RULES GO OR PERMITS ONLY 9.30-10.30

Congestion Zone: No / Yes

Access: Easy / Hard / 2 men req'd / 1st - 2nd floor?

Runners: ~~Whipping~~ / Binding (if binding, specify type)

Tape size: ~~1 1/2"~~ / 2" / 3" / 5"

Style: ~~Top~~ taping / Side binding

Stairrods: Type _____ Nr _____ Size _____

Must Read: Meet customer on site