

P2883A
 BLYOGES
 50 RUSHAME ROAD
 SWIS 3LG

H/SIL
FREEDOM TRUST
COLOUR 841 DOLPHIN

Row 1 600 x 400
 Row 2 400 x 400
 Row 3 430 x 400
1430 x 400

5720m²

P28834
 BRIDGES
 50 RUSHMORE ROAD
 SWIS 3LG

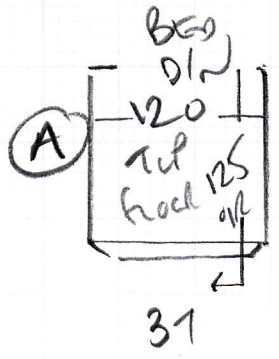

45 x 118

* B/W 61
 45 x 110 45 x 87

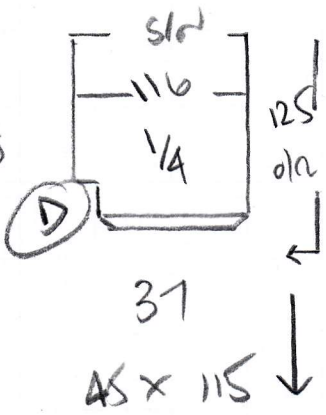
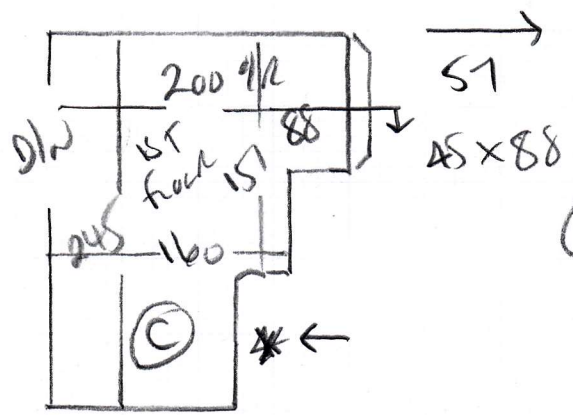
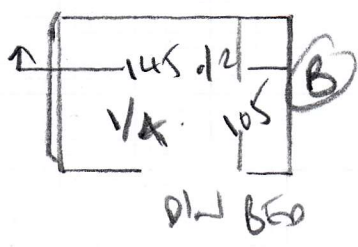

37
 45 x 115

To Have

* B/W 61
 * 60 x 130 47 x 103 45 x 88

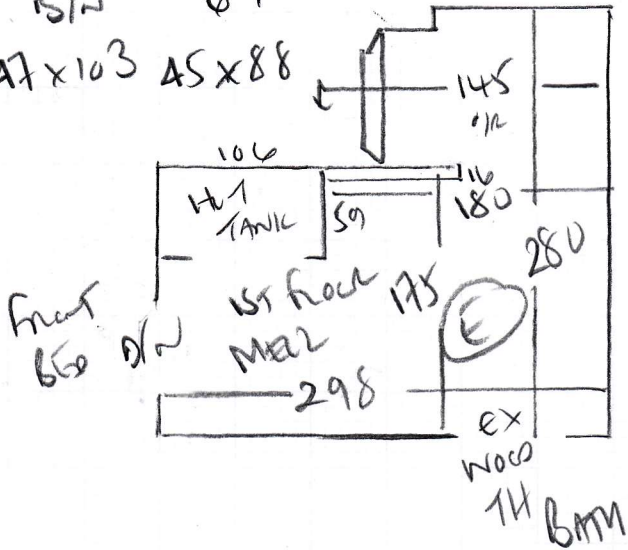

P28834
 BL 106ES
 50 RUSTHOLME ROAD
 SWIS 3LG

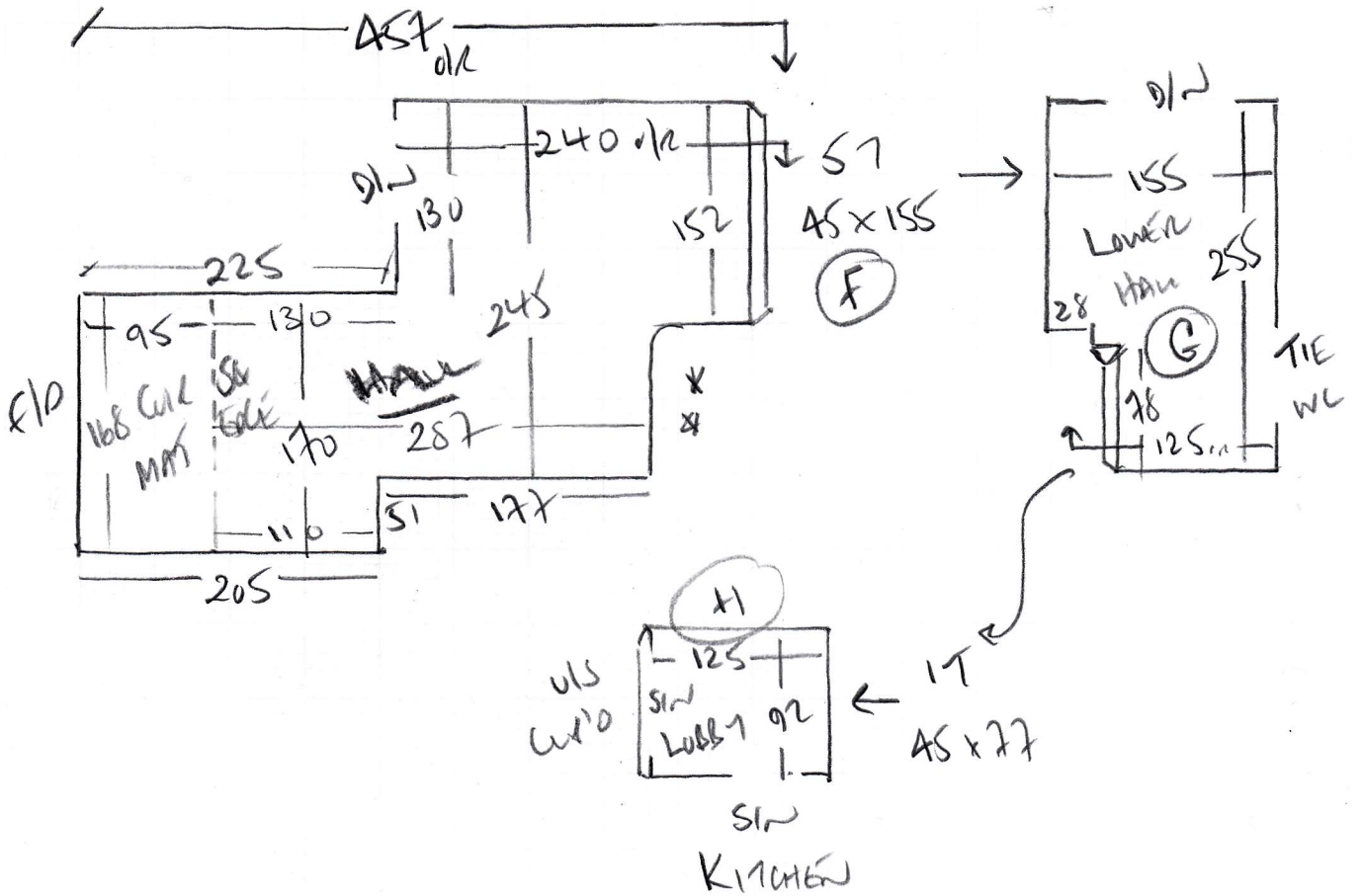

Mrs Maryse Brydges, 50 Rusholme Road

Date of Measure: Thu, 24 Jan 19

At: 10am

Site Address:
50 Rusholme Road

Customer Address:
50 Rusholme Road

LONDON SW15 3LG

LONDON SW15 3LG

CONTACT: As customer details

Mobile	Home	Office
	020-8788-3329	

Email:
marysebrydges@gmail.com

Areas to be done and Description of Measure

Stairs & Lands for [1]Freedom Twist-Dolphin [2]Suede-SUD-626. Entrance Lobby for Amtico Signature or Decor - CONFIRM WHICH!

Q u a e 1) Freedom Twist 841 Dolphin

2) Silex Freedom 841 Dolphin

HANDSCAM LANDINGS REQUESTS BUT NOT POSSIBLE AS
LOTS OF WIRES ON 3x MAN LANDINGS!!

Instructions and Estimators comments

Check size for coir mat in lobby. Cust has concern about moths.

100m x 200m CAR MAT
OR RE-USE EXISTING (Brown)

SEND SAMPLES Freedom + Silex Freedom
Dolphin 841 (Both alternatives)

Must Read!

Customer will be home

Office Ref: P28834

Mrs Maryse Brydges, 50 Rusholme Road

Date of Measure Thu, 24 Jan 19

At 10am

Floor: Wood / Concrete / other _____

S/edge: Wood/Concrete/No pin/existing (if existing, allow sticks to supplement where necessary) *Alum*

Sticking Req'd: Yes/ No Type: Fastset/Other

Underlay: Re-use Existing / New required

Type: 42oz Felt / Fomalux / PU Foam / Luxury PU Foam / LowTog / Durafit

Doorbars: Alloy / Satin Ali / Polished Ali / Anod^{en} / Solid Brass / Chrome / Nisheen
Seam/Wood/T/Holds: colour _____

Door Clearance: OK / Low (advise on quote)

Uplift: No / Yes (if "Yes" - what type?) *ADVISE OTHERS TO DO MATS!!
UPLIFT & LEAVE IN SMALL BUNDLES
FOR CUSTOMER TO DISPOSE OF*

Furniture: No/Yes (if YES, please specify the following) - 1 man / 2 men (Fitter to get paid) £_____ total/per room

Parking Cost: Free / £_____ per hour

Parking Restrictions: (type) / £ 930 - 1030AM Perm 10 only

Congestion Zone: No / Yes

Access: Easy / Hard / 2 men req'd / Grd - 2nd floor?

Runners: Whipping / Binding (if binding, specify type)

Tape size: 1½" / 2" / 3" / 5"

Style: Top taping / Side binding

Stairrods: Type _____ Nr _____ Size _____

Must Read: Customer will be home