

WC + Utility Room

P29013
 AR GUIDE
 18 Bundstock Room
 SWIS 2/W

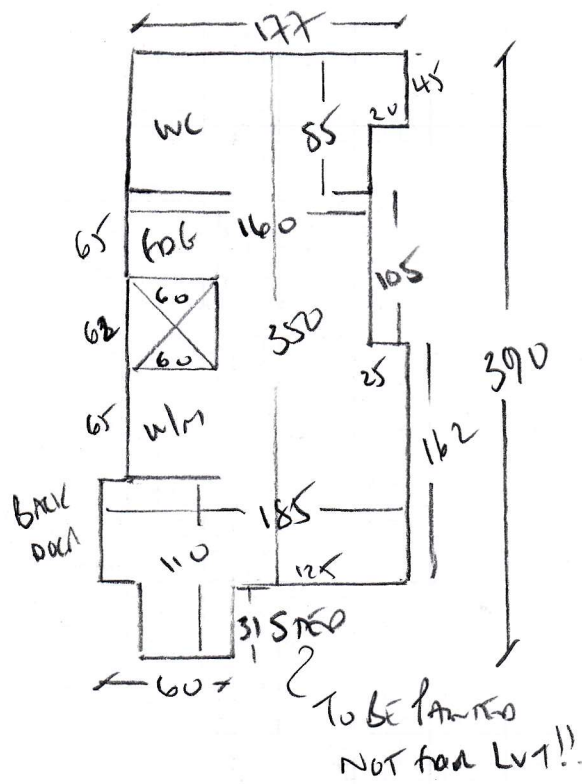

MODIFIED 'SELECT'
Colour _____

TILES 329 x 659
 @ 390m² per box

2 boxes @ 390m² = 780m²

CONCRETE floor (DIM??)
 NO UPSTAIRS
 NO SKIRTINGS ON?
 \ BUILDER TO CHECK?

CUSTOMER - ADVISED COLIN ON SITE THAT THEIR OWN BUILDER
 WILL PREPARE SUB-FLOOR - (THEY NEED TO CHECK IF DIM EXISTS?)
 THEREFORE FURTHER SITE VISIT REQUIRED TO CHECK BUILDER'S PREP.
 BEFORE WE CAN CONFIRM EXACT PRICE / QUOTE

P29013

2nd call of 3

Notes for Measure

Estimator: Colin

Ms Tasha Arguile, 18 Burstock Road

Date of Measure: Tue, 7 May 19

At: 10-11am

Site Address:

18 Burstock Road
Putney

LONDON

SW15 2PW

Customer Address:

18 Burstock Road
Putney

LONDON

SW15 2PW

CONTACT: As customer details

Mobile	Home	Office
07754-734070	020-8788-4554	N/P

Email:

tjarguile@hotmail.com

Areas to be done and Description of Measure

Utility Room + WC for Moduleo Select Jetstone 46982 / Cantera 46930 (NO STRIPPING) Discuss step?

! CUSTOMER TO
PAINT STEP
NOT FOR LV1!!
==

Instructions and Estimators comments

Check prep required - should be newly levelled? Appliances?

↑ NOT DONE YET!!

Must Read!

Tashe or Dad (Robert) to be home

Office Ref: P29013

Ms Tasha Arguile, 18 Burstock Road

Date of Measure Tue, 7 May 19

At 10-11am

Floor: Wood / Concrete / other To be levelled by builder
Builder to check if DPM exists?

S/edge: Wood/Concrete/No pin/existing (if existing, allow ___ sticks to supplement where necessary)
Allow for feathered finish over builders screed!

Sticking Req'd: Yes/No Type: Fastset/Other

Underlay: Re-use Existing / New required

Type: 42oz Felt / Fomalux / PU Foam / Luxury PU Foam / LowTog / Durafit

Doorbars: Alloy / Satin Ali / Polished Ali / Anod / Solid Brass / Chrome / Nisheen
 Seam/Wood/T/Holds: colour NONE

Door Clearance: OK / Low (advise on quote)

Uplift: No / Yes (if "Yes" - what type?) _____

Furniture: No/Yes (if YES, please specify the following) - 1 man / 2 men (Fitter to get paid) £ _____ total/per room
FRIDGE + WASHING MACHINE TO MOVE

Parking Cost: Free / £ 260 per hour

Parking Restrictions: (type) / £ permits only - talk to property owner
(PONDENAGE)

Congestion Zone: No / Yes

Access: Easy / Hard / 2 men req'd / CONCRETE floor? MUST BE CHECKED
+ BUILDERS SUB-FLOOR

Runners: Whipping / Binding (if binding, specify type)
INSPECT BEFORE

Tape size: 1 1/2 / 2" / 3" / 5"
PROCEEDING WITH
AN ORDER

Style: Top taping / Side binding

Stairrods: Type _____ Nr _____ Size _____

Must Read: Tashe or Dad (Robert) to be home