

Job No: P27227  
 Name: MUTH  
 Address: A CASTELLO AVENUE  
 SWISS BEA  
 Tel:  
 Sheet: at

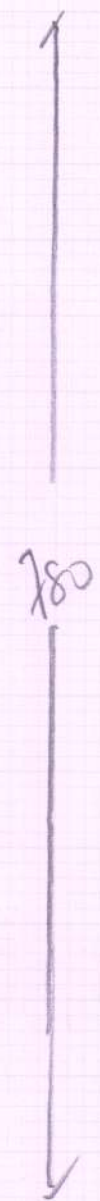
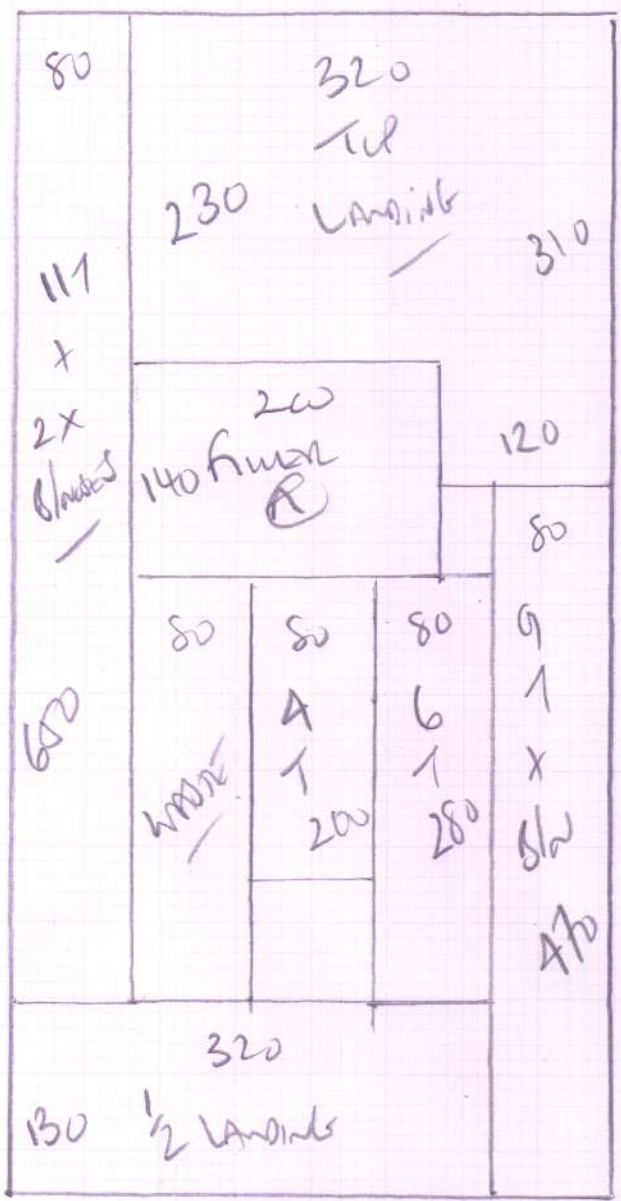

Big five  
 Color - 193

Plan 1 780 x 400  
 Plan 2 400 x 400  
 Guest Bed 11475 x 400  
 1655 x 400

16.20 m<sup>2</sup>

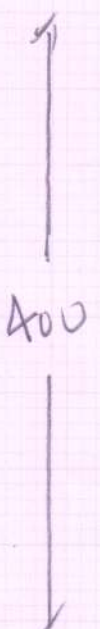

mrcarpets  
 Job No: P29227  
 Name: MWH  
 Address: A CASTLE AVENUE  
 SWISSEA  
 Tel:  
 Sheet: of

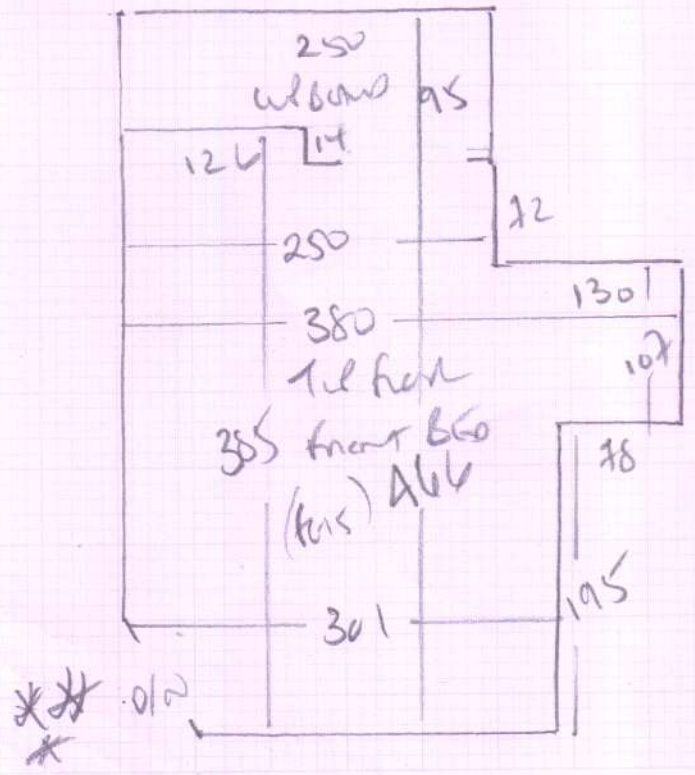
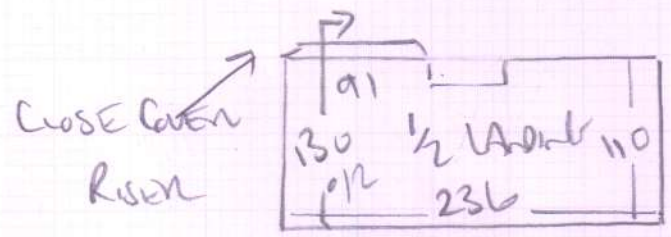
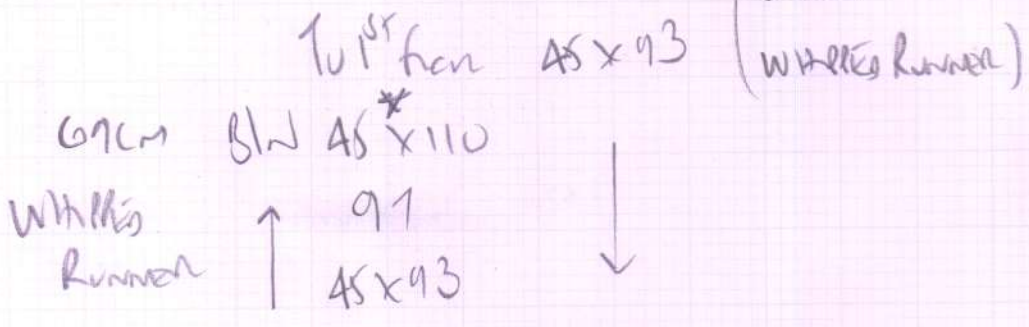
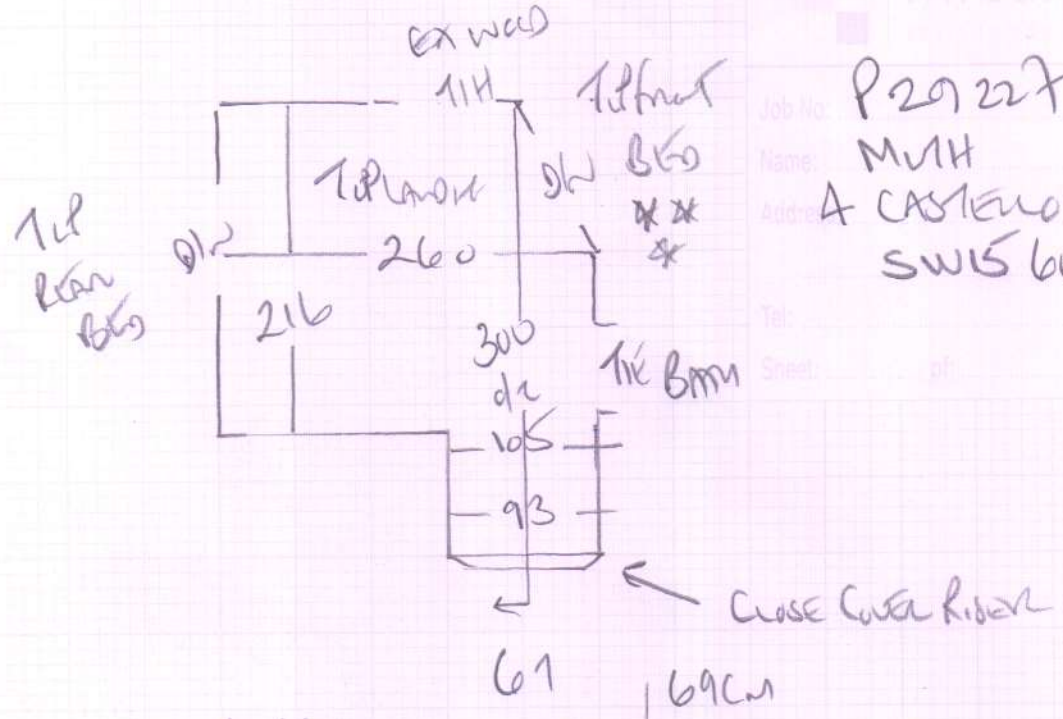

Job No: P29227  
 Name: MUTH  
 Address: 4 CASTRO AVE  
 SWISSEA  
 Tel: \_\_\_\_\_  
 Sheet: \_\_\_\_\_ of \_\_\_\_\_

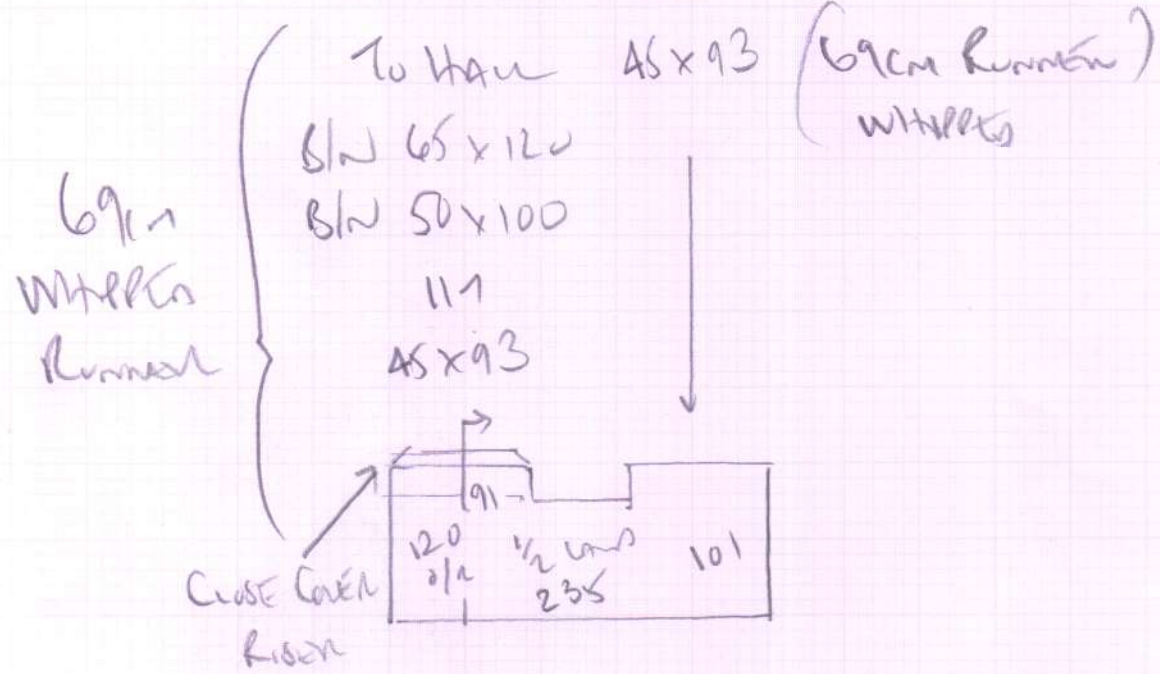
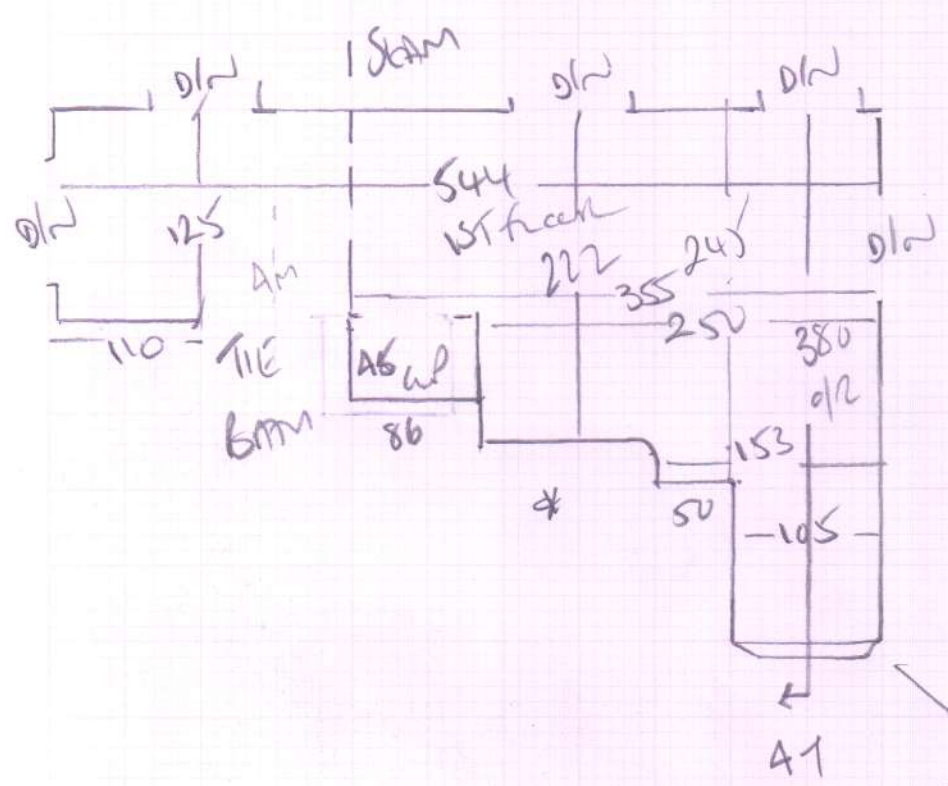

P29227

1st call of 4

Notes for Measure

Estimator: Colin

Mr & Mrs Muth, 4 Castello Avenue

Date of Measure: Wed, 4 Sep 19

At: 9am

Site Address:  
4 Castello Avenue

Customer Address:  
4 Castello Avenue

LONDON SW15 6EA

LONDON SW15

CONTACT: Mark & Lorraine

Mobile	Home	Office
07771-850199	020-8789-4332	Not known

Email:  
lorrainemth0@gmail.com

Areas to be done and Description of Measure

Q1) S/L & 1 bedroom for Big Five-193 @ £16m<sup>2</sup> (Runner to all stairs) Q2) 2 other beds for plain carpet to select

Instructions and Estimators comments

Q3) Art Room a) Plain cpt to select b) Avenue C/Flor to select \*\* Fitting not req until Nov

**Must Read!**

**Reserve Big Five stock when quantity known**

Office Ref: P29227

Mr & Mrs Muth, 4 Castello Avenue

Date of Measure Wed, 4 Sep 19

At 9am

Floor:

Wood / Concrete / other W/ Down

S/edge:

Wood/Concrete/No pin/existing (if existing, allow 10 sticks to supplement where necessary)

Sticking Req'd:

Yes/No No Type: Fastset/Other

Underlay:

Re-use Existing / New required

Type:

42oz Felt / Fomalux / PU Foam / Bugs / Luxury PU Foam / Removers / LowTog / Durafit

Doorbars:

Alloy / Satin Ali / Polished Ali / Anod / Solid Brass / Chrome / Nisheen Seam/Wood/T/Holds: colour         

Door Clearance:

OK / Low (advise on quote)

Uplift:

No / Yes (if "Yes" - what type?) Level line on Rubata 1st floor door  
Work on Rubra 1/2 floor

Furniture:

No/Yes (if YES, please specify the following) - 1 man / 2 men (Fitter to get paid) £ 70 total/per room

Parking Cost:

Free / £ 2.90 per hour

Parking Restrictions:

(type) / £ Rmk 60

Congestion Zone:

No / Yes No

Access:

Easy / Hard / 2 men req'd / 1st floor floor?

Runners:

X Whipping / Binding (if binding, specify type)

Tape size:

1 1/2" / 2" / 3" / 5"         

Style:

Top taping / Side binding

Stairrods:

Type X Nr X Size         

SIL  
DRAFT  
CHECK WORK  
WITH SOURCE  
WORKING  
SALIC

**Must Read: Reserve Big Five stock when quantity known**