

R18232
 WALKER
 11 BELVEDERE GROVE
 SWING FLOOR

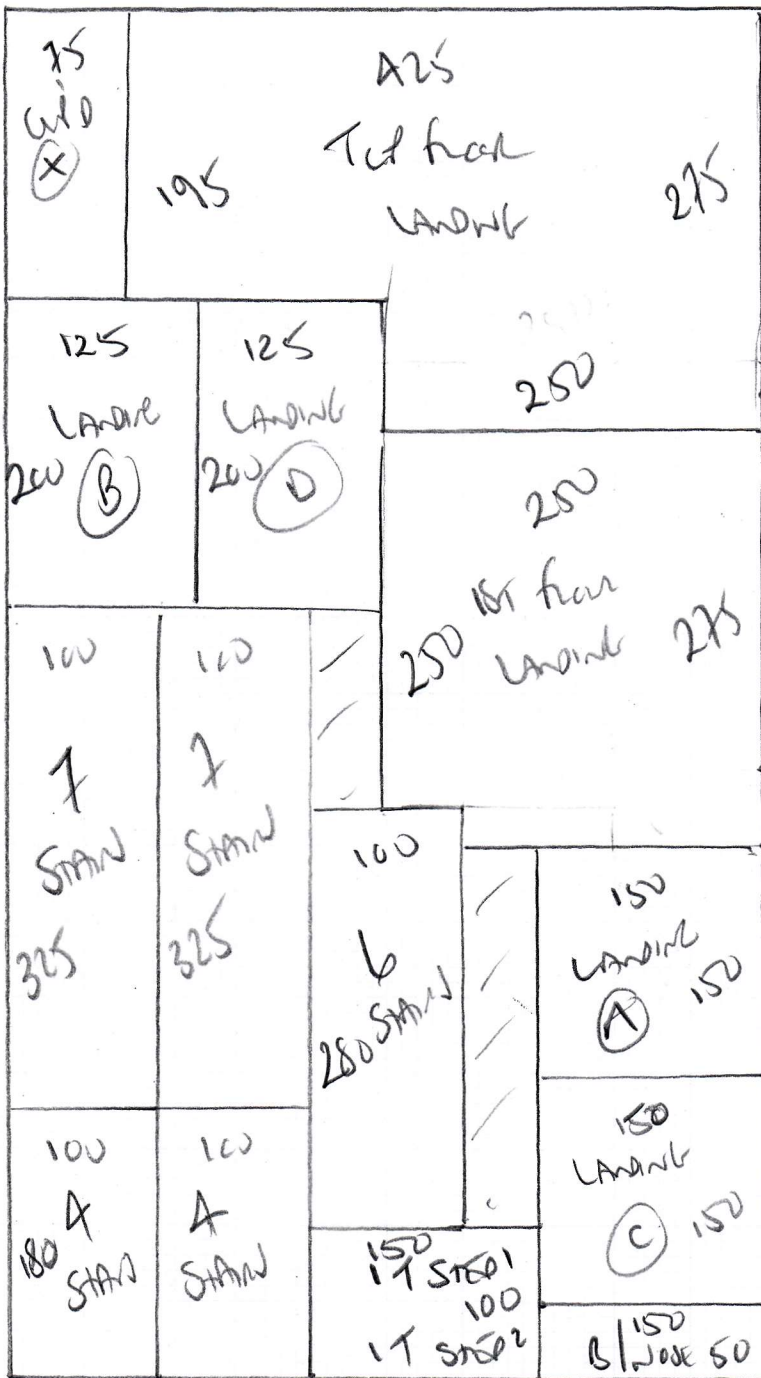

STAIR + LANDINGS

BELGRAVE'S 5002
 CAROL BELSIS

PLAN 900 x 500

900

45 m²

R18232
WALKER
11 BOWEN ST BRISBANE
SWING FLOOR

A BEDROOMS

RUGGED 1m x 500
COVER Rv1 50 E 60

1st floor front BED

430 x 500

1st floor rear BED

530 x 500

CHECK MEASURE
BEFORE ORDERING

1st floor front BED

440 x 500

1st floor rear BED

570 x 500

TOTAL 1970 x 500

98.50m²

R18232
 WALKER
 11 BELVEDERE GROVE
 SW19 FLA.

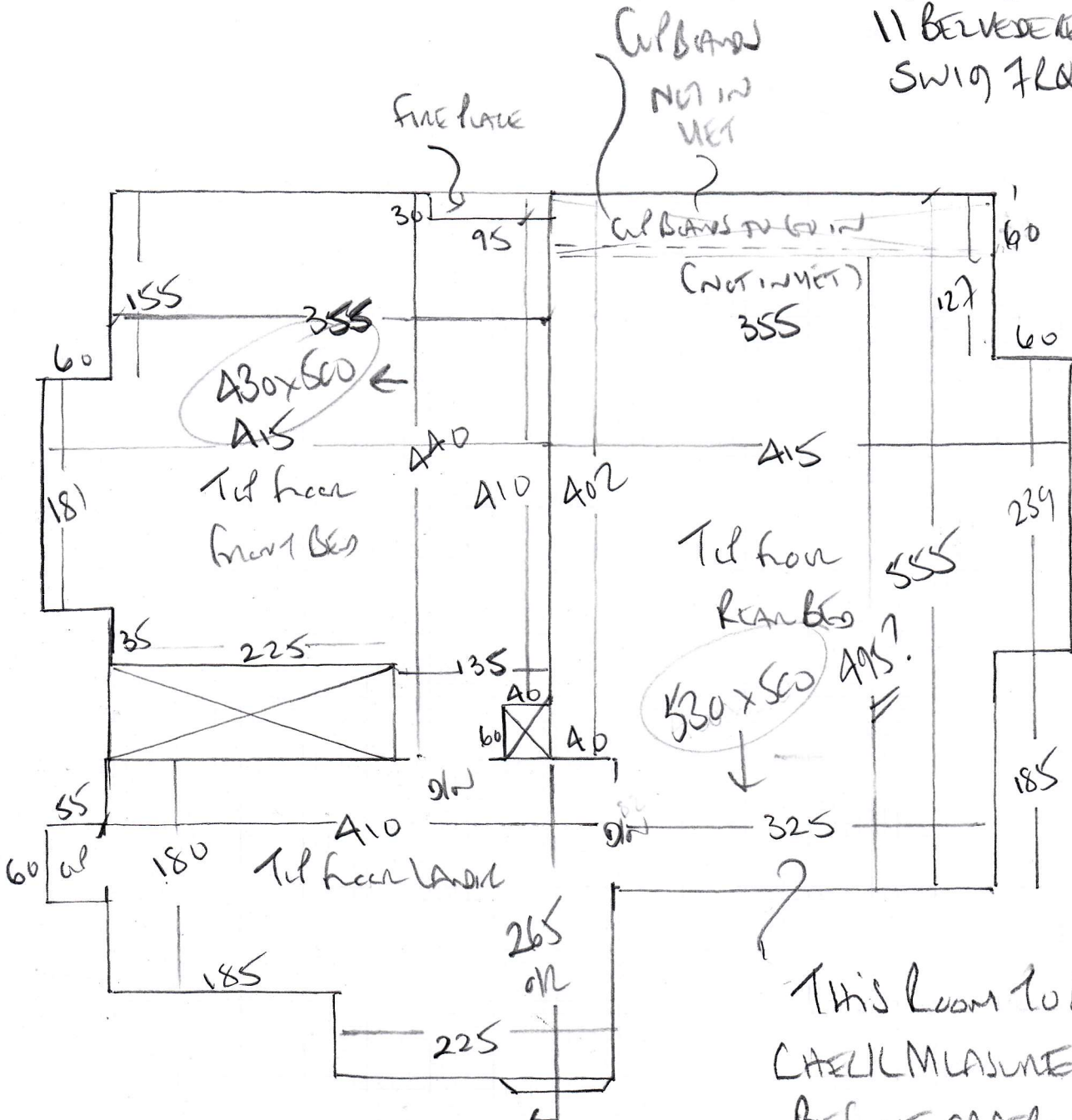

THIS ROOM TO BE
 CHECK MEASURED
 BEFORE ORDERING CUPB.
 CUPBOARDS NOT BUILT YET!!

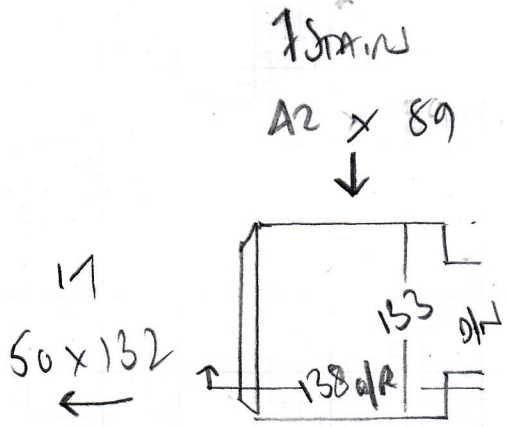
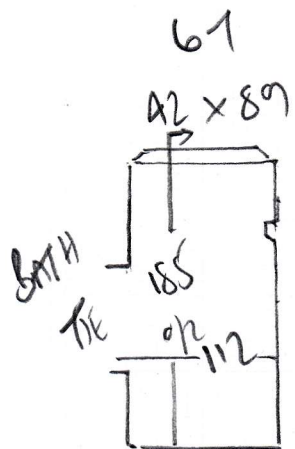

R18232
 WALKER
 11 BAY/50 BAY/60 BAY
 SWING FILE

CUPBOARDS
 NOT IN ME1

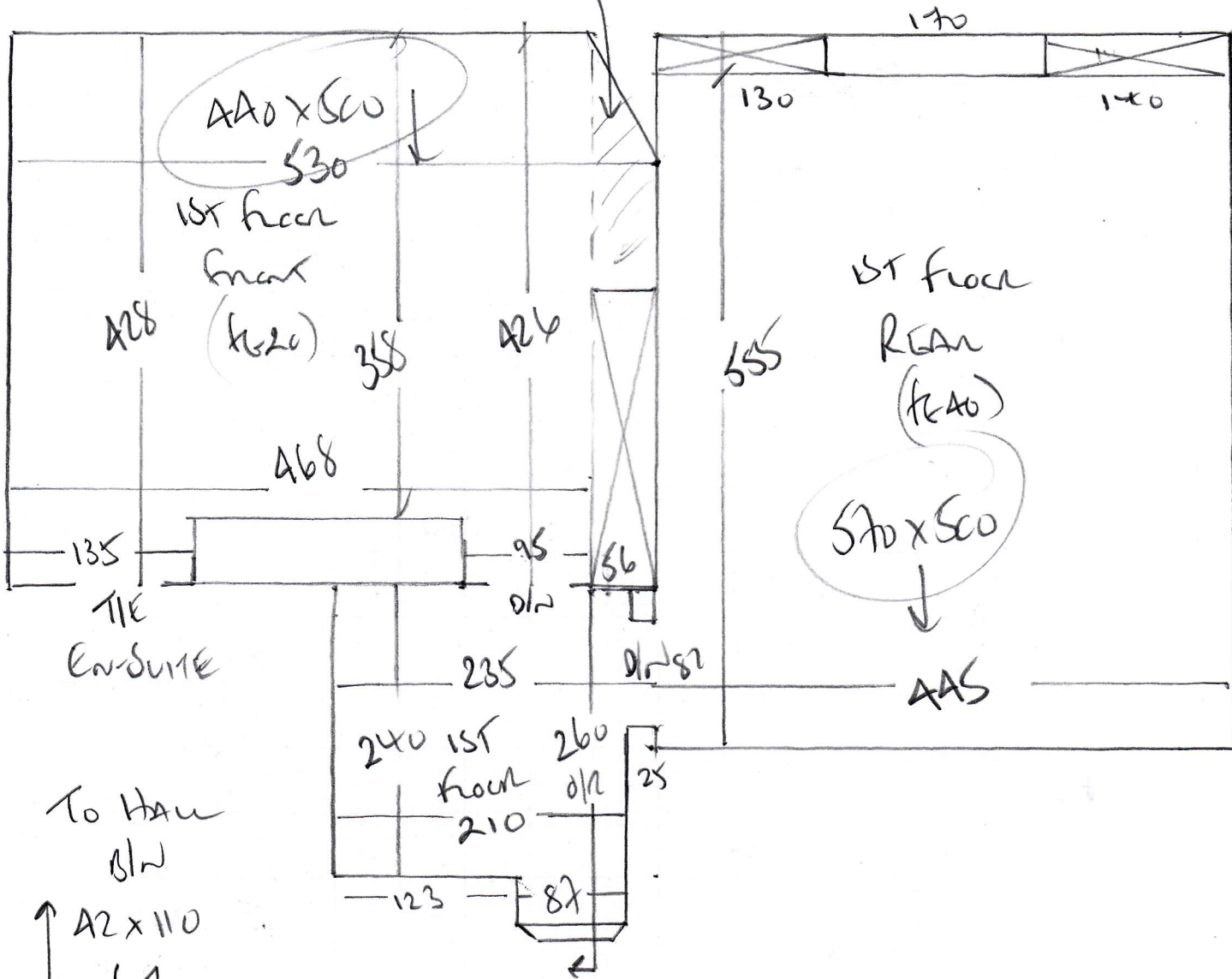

To Hall
 Blw
 ↑ A2 x 110
 61
 A2 x 89

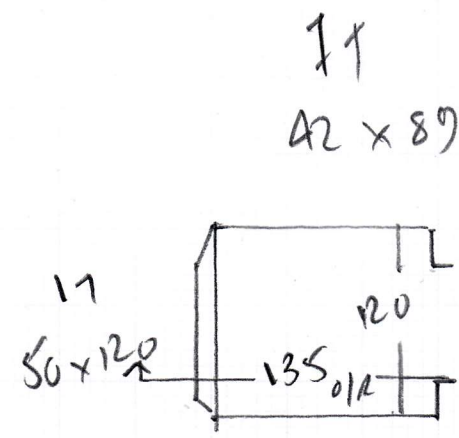
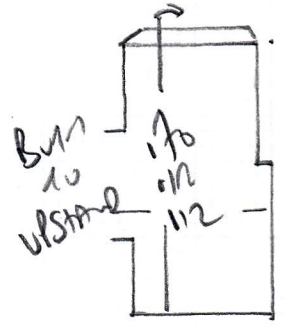

Mrs Kasia Walker, 11 Belvedere Grove

Date of Measure: Wed, 18 Sep 19

At: 12-1pm

Site Address:
11 Belvedere Grove

Customer Address:
11 Belvedere Grove

LONDON SW19 7RQ

LONDON SW19 7RQ

CONTACT: As customer details

Mobile	Home	Office
07525-147365		

Email:
kasia.w@hotmail.co.uk

Areas to be done and Description of Measure

stairs/landings from ground to top, first floor brooms and top bedrooms rutland col E60 to stairs Belgrave 153 to some rooms

Instructions and Estimators comments

all areas twist but different colours for S/L, 2nd colour for 1st floor rooms, 3rd colour top rooms

Handwritten: Gantt Schedule

Handwritten: PHASE 1 - 1st floor 2 Beds

Handwritten: PHASE 2 - 1st floor 2 Beds

Handwritten: Gantt Phase - STAIRS + LANDINGS

Must Read!

12-1pm

Office Ref: R18232

Mrs Kasia Walker, 11 Belvedere Grove

Date of Measure Wed, 18 Sep 19

At 12-1pm

Floor: Wood / Concrete / other _____

S/edge: Wood/Concrete/No pin/existing (if existing, allow __ sticks to supplement where necessary)

Sticking Req'd: Yes/ No Type: Fastset/Other

Underlay: Re-use Existing / New required

Type: 42oz Felt / Fomalux / PU Foam / Luxury PU Foam / LowTog / Durafit
+ ceiling?

Doorbars: Alloy / Satin Ali / Polished Ali / Anod / Solid Brass / Chrome / Nisheen
Seam/Wood/T/Holds: colour _____

Door Clearance: OK / Low (advise on quote)

Uplift: No / Yes (if "Yes" - what type?) SLC + 1st floor 2 bears

Furniture: No/ Yes (if YES, please specify the following) - 1 man / 2 men (Fitter to get paid) £ 20 total/per room

Parking Cost: Free / £ 3.00 per hour 1 Hour MAXIMUM

Parking Restrictions: (type) / £ ON DRIVEWAY WITH PERMISSION

Congestion Zone: No / Yes

Access: Easy / Hard / 2 men req'd / 1st + 20 floor?

Runners: Whipping / Binding (if binding, specify type)

Tape size: ~~1 1/2"~~ / 2" / 3" / 5"

Style: Top taping / Side binding

Stairrods: Type _____ Nr _____ Size _____

Room E + Room H?
2 x Room MEZANINE
BED ROOMS TO REMAIN
AT EXISTING LEVELS

Must Read: 12-1pm

Office Ref: R18232