

Job No: R18268
Name: CLARK
Address: 9 THE FARMWAY
RAINES LANE
Tel: SW20 9DN
Sheet: of:

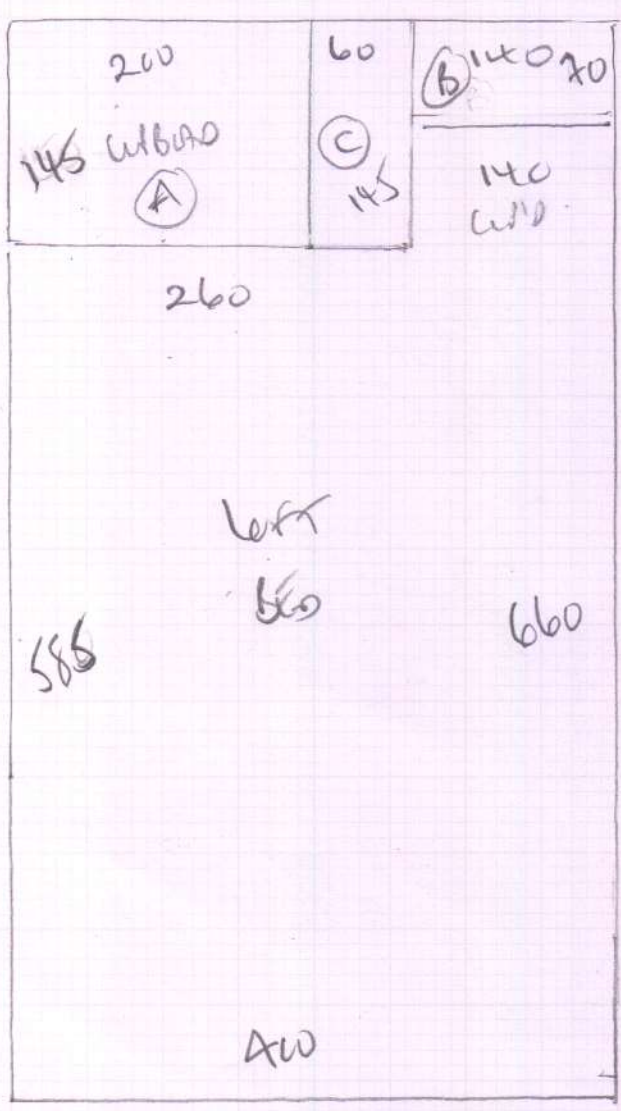

Left Bedroom
+ INTO W/BANDS

Subbing Inst 'Sooz'
Coral 635/

Plan 730 x 400

29.20m²

Job No: R18268
 Name: CLANK
 Address: 9 THE FARWAY
 RAINES PARK
 SW20 90W
 Tel: _____
 Sheet: _____ of _____

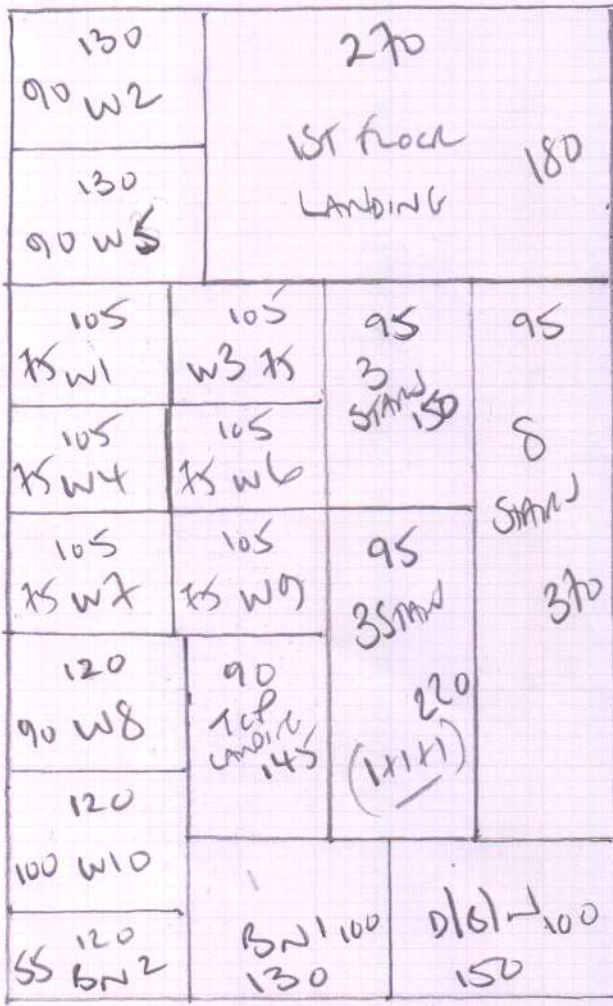

650

STAND + LANDINGS
1st floor to ground floor

MACEDONIA
 Colour 609/37

RAW 650 x 400

26m²

Job No: R18268
 Name: CLANK
 Address: 9 THE FAIRWAY
 FARMES PARK
 SW20 9DN
 Tel: _____
 Sheet: _____ of _____

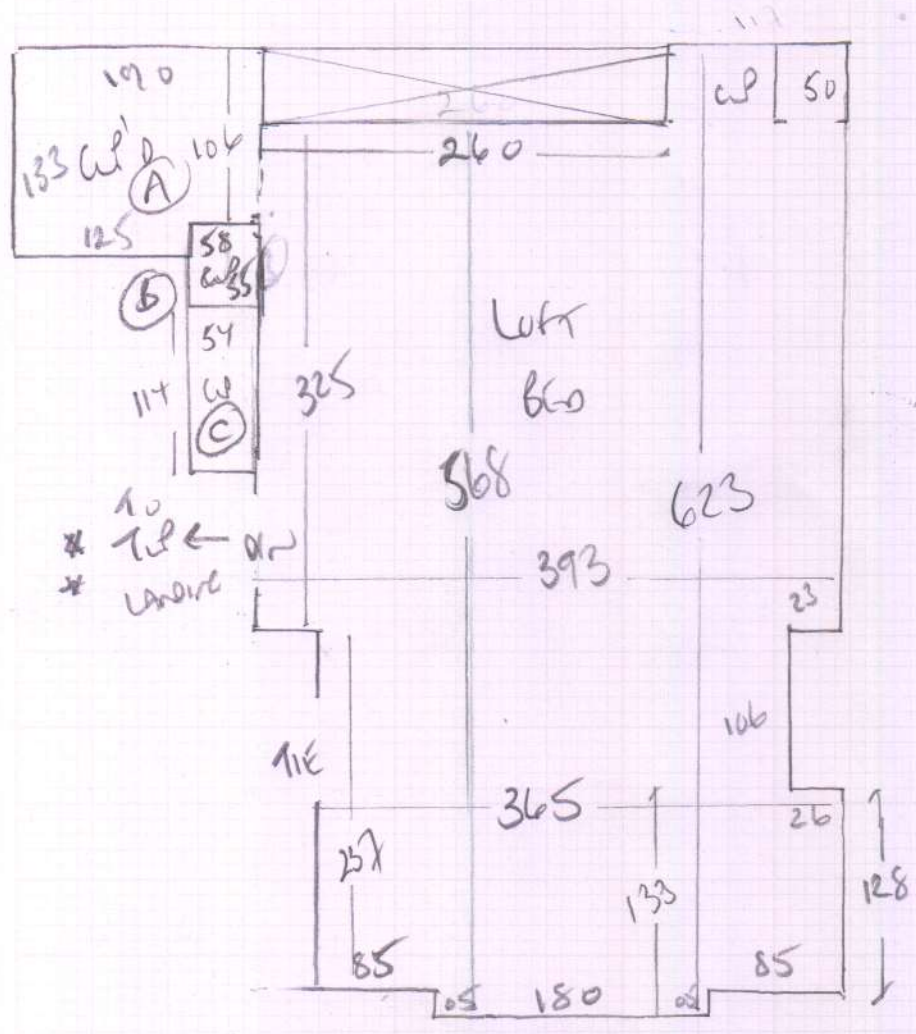

- NEW Loft Conversion
- WOOD FLOOR
- NO PLINTH
- NO HANDRAIL
- ALL DOORS
- FIT INTO WPCANDS (x 5)

mrcarpet
 Job No: R 18268
 Name: CLARK
 Address: 9 THE FAIRWAY
 RAJES LANE
 Tel: SW20 90W
 Sheet: of:

Toilet from Landmark

BN 1 65 x 120

BN 2 46 x 95

↑ IT
 IT 45 x 77
 WB 69 x 73
 WS 75 x 108
 W4 65 x 89

↑ 31
 46 x 78
 W3 68 x 75
 W2 75 x 108
 W1 65 x 87

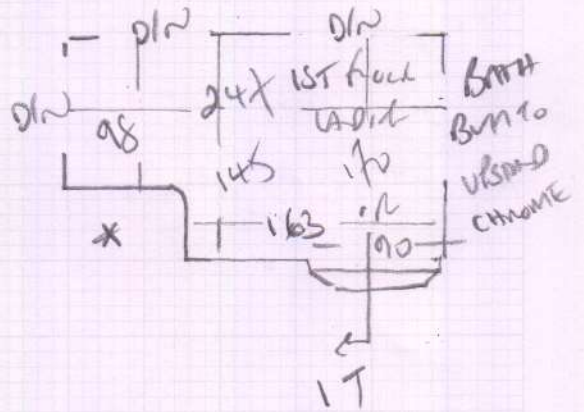
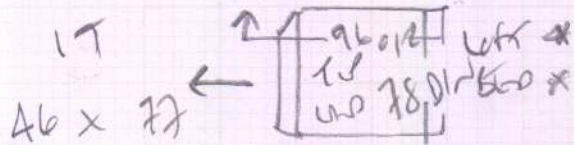

↓ IT
 42 x 81
 W7 62 x 92
 W8 75 x 114
 W9 68 x 78
 81
 40 x 81

W10 91 x 110
 D/S/W 50 x 120
 (CAR + BATH)

To Grandfather Hall
 (wood floor)

R18268

1st call of 2

Notes for Measure

Estimator: Colin

Mrs Fiona Clark, 9 The Fairway

Date of Measure: Tue, 26 Nov 19

At: 8.00am Prompt

Site Address:
9 The Fairway

Customer Address:
9 Fairway

LONDON SW20 9DN

LONDON SW20 9DN

CONTACT: As customer details

Mobile	Home	Office
	020	07740-867287

Email:
clarkfi72@gmail.com

Areas to be done and Description of Measure

stairs from ground to loft plus loft room and first floor front bedroom

Macedonia
Send IMAGES of Pinstripes ON WINDOWS 26/11/19

Final Date Required 18th, 19th 20th DECEMBER

Instructions and Estimators comments

macedonia 609/37 sample ordered for stairs ground to first and ~~Linton Twist~~ for other areas (226 or

Send sample with date
Supply Twist 42' case 31/23

Must Read!

Customer has to leave home by 8.30am PROMPT

Office Ref: R18268

Mrs Fiona Clark, 9 The Fairway

Date of Measure Tue, 26 Nov 19

At 8.00am Prompt

Floor: Wood / Concrete / other _____

S/edge: Wood/Concrete/No pin/existing (if existing, allow ___ sticks to supplement where necessary)

Sticking Req'd: Yes No Type: Fastset/Other

Underlay: Re-use Existing / New required

Type: 42oz Felt / Fomalux / PU Foam / Luxury PU Foam / LowTog / Durafit

Doorbars: Alloy / Satin Ali / Polished Ali / Anod / Solid Brass / Chrome / Nisheen
Seam/Wood/T/Holds: colour _____

Door Clearance: OK / Low (advise on quote) *NOT HUNG UP ON LEFT ROOM*

Uplift: No / Yes (if "Yes" - what type?) *1st floor + Landing only*

Furniture: No/Yes (if YES, please specify the following) - 1 man / 2 men (Fitter to get paid) £_____ total/per room

Parking Cost: Free / £_____ per hour

Parking Restrictions: (type) / £ *ON DRIVEWAY WITH PERMISSION?*
OR ACROSS DRIVEWAY

Congestion Zone: No / Yes

Access: Easy / Hard / 2 men req'd / _____ floor? *LOFT BED (TOO HEAVY FOR 1 MAN?)*

Runners: Whipping / Binding (if binding, specify type)

Tape size: 1 1/2" / 2" / 3" / 5"

Style: Top taping / Side binding

Stairrods: Type _____ Nr _____ Size _____

Must Read: Customer has to leave home by 8.30am PROMPT