

Job No: Colgan  
Name: S35943  
Address: S35943

Tel: \_\_\_\_\_  
Sheet: \_\_\_\_\_ of: \_\_\_\_\_

When NAV-914.

TOP floor

The  
fire  
closets.

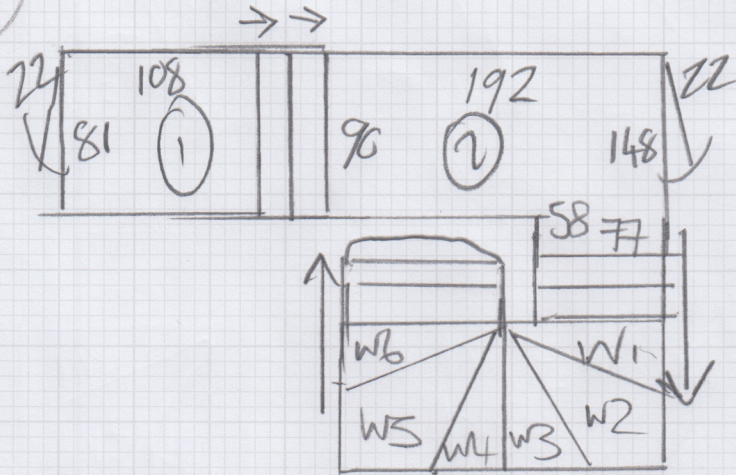

2@.50x70  
2@.50x66

- W1 = 68 x 72
- W2 = 75 x 95
- W3 = 65 x 65
- W4 = 70 x 75
- W5 = 75 x 95
- W6 = 65 x 66
- 3@.50x67

BN=60x78

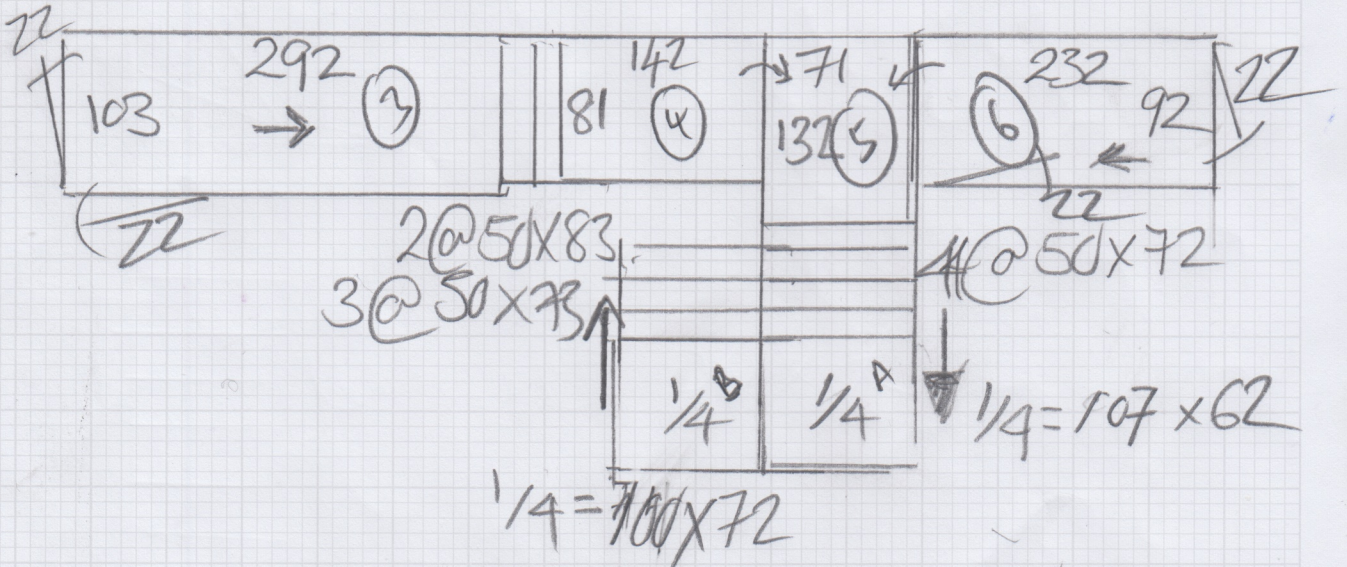

2@50x83  
3@50x73

1@50x72

1/4 = 107 x 62

1/4 = 100 x 72

Mrs Selina Colgan, 38 Thorne Street

Date of Measure Mon, 24 Nov 25

At 12-1pm

Floor: Wood / Concrete / other \_\_\_\_\_

S/edge: Wood/Concrete/No pin/existing (if existing, allow \_\_\_ sticks to supplement where necessary)

Sticking Req'd: Yes/No Type: Fastset/Other

Underlay: Re-use Existing / New required

*Put separately*

Type: 42oz Felt / Fomalux / PU Foam / Luxury PU Foam / LowTog / Durafit

*ball*

Doorbars: Alloy / Satin Ali / Polished Ali / Anod / Solid Brass / Chrome / Nisheen  
Seam/Wood/T/Holds: colour

*Existing*

Door Clearance: OK / Low (advise on quote)

Uplift: No / Yes (if "Yes" - what type?)

*add as extra*

Furniture: No/Yes (if YES, please specify the following) - 1 man / 2 men (Fitter to get paid) £ \_\_\_\_\_ total/per room

Parking Cost: Free / £ \_\_\_\_\_ per hour

Parking Restrictions: (type) / £ \_\_\_\_\_

*Permit available for cars*

Congestion Zone: No / Yes

Access: Easy / Hard / 2 men req'd / \_\_\_\_\_ floor?

Runners: Whipping / Binding (if binding, specify type)

Tape size: 1½" / 2" / 3" / 5"

Style: Top taping / Side binding

Stairrods: Type \_\_\_\_\_ Nr \_\_\_\_\_ Size \_\_\_\_\_

Must Read: Customer will be home