

DATE	REV	DESCRIPTION
04/02/20	A	REVISIONS PER CLIENT MEETING

M 1:50  
0 0,5 1,0 1,5 2,0 2,5 3,0 3,5 [m]

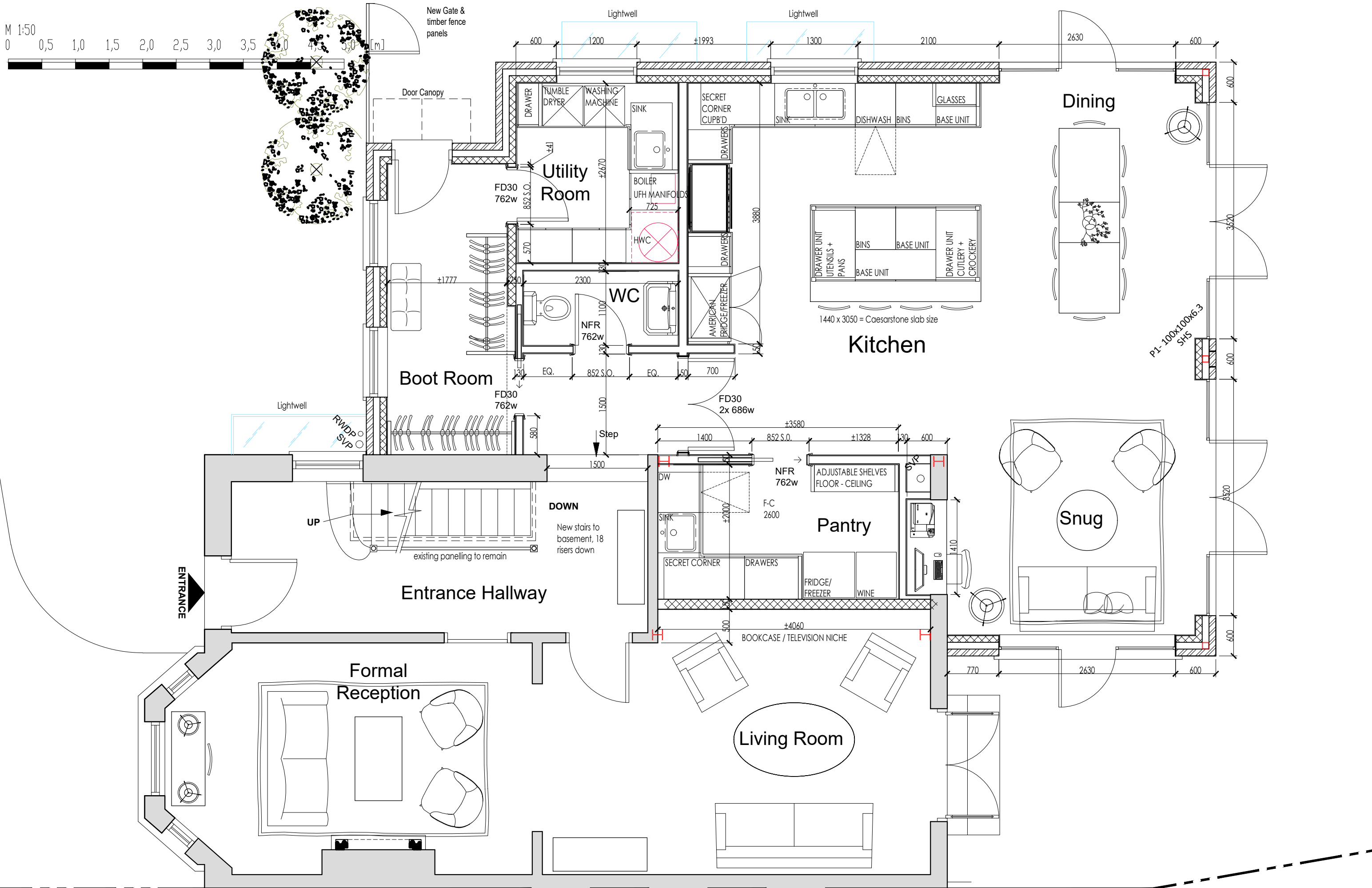

GROUND FLOOR  
07 Jan 2020  
1:50 @A3 / 1:100 @A4

Adjoining property  
No 2

DATE	REV	DESCRIPTION
07/01/20	A	AMEND CRITCAL DOOR DIMENSIONS
23/01/20	B	AMENDMENTS
30/01/20	C	REVISIONS PER CLIENT MEETING
04/02/20	D	REVISIONS PER CLIENT MEETING



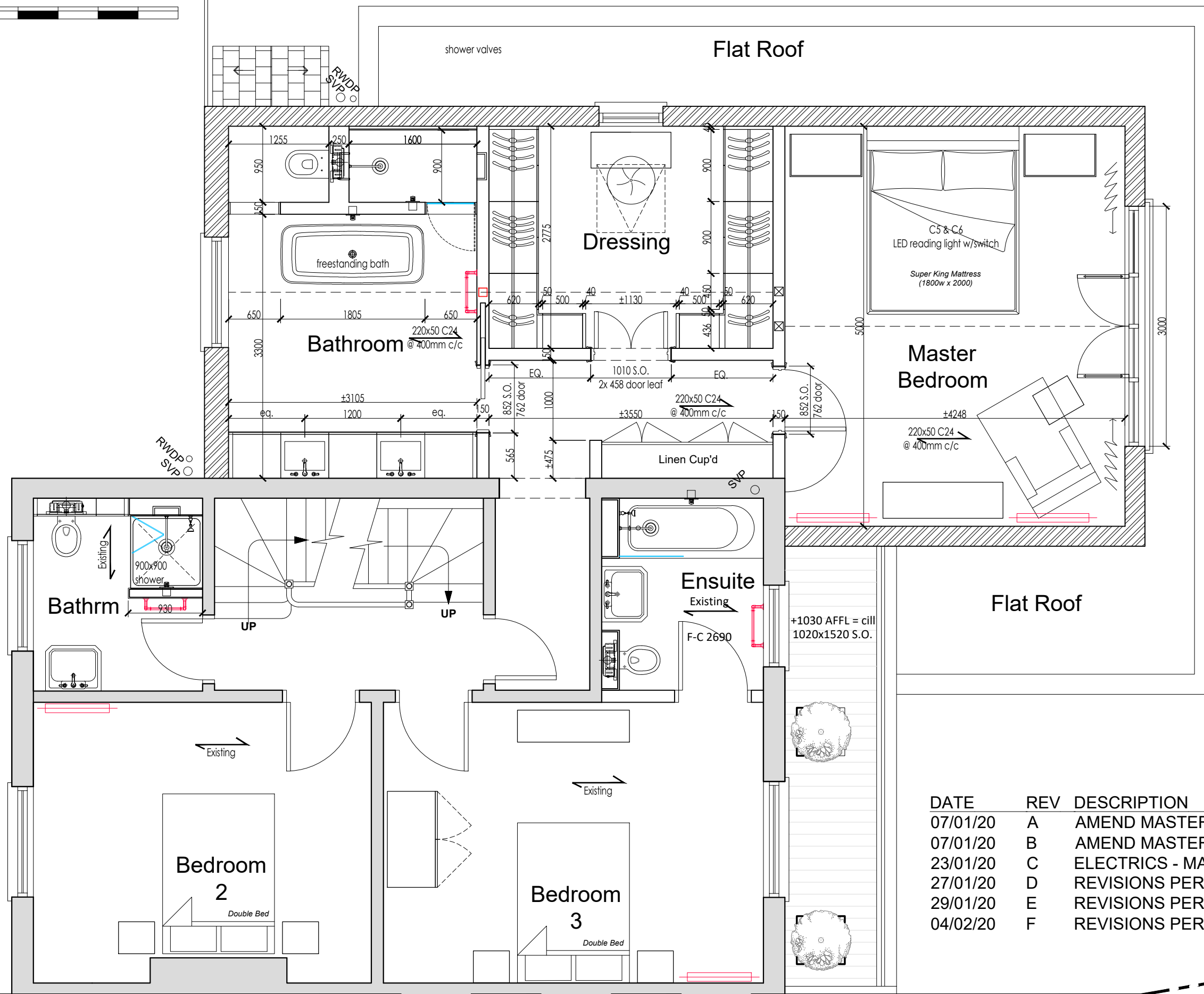
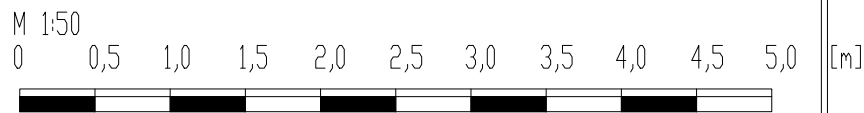

DATE	REV	DESCRIPTION
07/01/20	A	AMEND MASTER BEDRM DIMENSIONS
07/01/20	B	AMEND MASTER DRESSING/ENSUITE
23/01/20	C	ELECTRICS - MASTER SUITE
27/01/20	D	REVISIONS PER CLIENT MEETING
29/01/20	E	REVISIONS PER CLIENT MEETING
04/02/20	F	REVISIONS PER CLIENT MEETING

FIRST FLOOR  
 07 Jan 2020  
 1:50 @A3 / 1:100 @A4

Adjoining property  
 No 2

## LIGHTING/LUMINAIRES

C*/N	C = circuit reference / N = Luminaire type reference
C*/a	RECESSED LED ADJUSTABLE DOWNLIGHT
C*/b	5Amp WALL SOCKET (CONTROLLED BY REMOTE LIGHT SWITCH)
C*/c	DECORATIVE PENDANT LIGHT
C*/d	SURFACE FIXED WALL LIGHT
C*/e	RECESSED MINIATURE LED DOWNLIGHT
C*/f	LINEAR LED TAPE LIGHT W/ ALUMINIUM CHANNEL & PLASTIC DIFFUSER
C*/g	SURFACE FIXED CEILING LIGHT
C*/h	SURFACE FIXED SPOT LIGHT
C*/i	FLOOR RECESSED MINIATURE LED UPLIGHT
C*/j	WALL RECESSED LED STEP LIGHT @ LOW-LEVEL
C*/k	SURFACED FIXED FLUORESCENT STRIP LIGHT
C*/m	SPIKE LED GARDEN LIGHT
	DOOR SWITCH ON MOTION SENSOR

## LIGHTING/SWITCHES

C*	C = circuit number reference
C*	ON/OFF SWITCH
C*	INTERMEDIATE SWITCH
C*	2-WAY SWITCH
C*	DIMMER SWITCH
C*	2-WAY DIMMER SWITCH
C*	DOOR CONTACT SWITCH

## ANCILLARY EQUIPMENT

T	THERMOSTAT
⊗	CEILING EXTRACTOR FAN LINKED TO LIGHT WITH OVERRIDE
⊗	WALL EXTRACTOR FAN LINKED TO LIGHT WITH OVERRIDE

## SMALL POWER

⏏	13A SINGLE SWITCHED SOCKET
⏏	13A DOUBLE SWITCHED SOCKET
⏏	UNSWITCHED FUSE SPUR
⏏	SWITCHED FUSE SPUR
⏏	ISOLATED SHAVER SOCKET
⏏	APPLIANCE SOCKET TO SUIT CONNECTION LOAD
⏏	ELECTRICAL DISTRIBUTION BOARD
MAI	MULTIPLE KITCHEN APPLIANCE ISOLATOR PANEL

## ALARMS

S	SMOKE DETECTOR
H	HEAT DETECTOR
CO	CARBON MONOXIDE DETECTOR

## COMMUNICATION / AUDIO VISUAL

BT	INCOMING MASTER BT POINT
▽	DATA POINT (RJ45 socket & Cat 6 with HDBase T certification)
▽	TELEPHONE SOCKET
TV	TV SOCKET
SP	CEILING SPEAKER
SP	SPEAKER SOCKET
HUB	NETWORK DISTRIBUTION PANEL

## SECURITY / ACCESS

DE	DOOR ENTRY PHONE
DE	DOOR ENTRY
SA	SECURITY ALARM PANEL
C	CCTV SECURITY CAMERA
MS	MOTION SENSOR

# 1

KEY / LEGEND  
SYMBOLS / DESCRIPTIONS  
SCALE 1:50

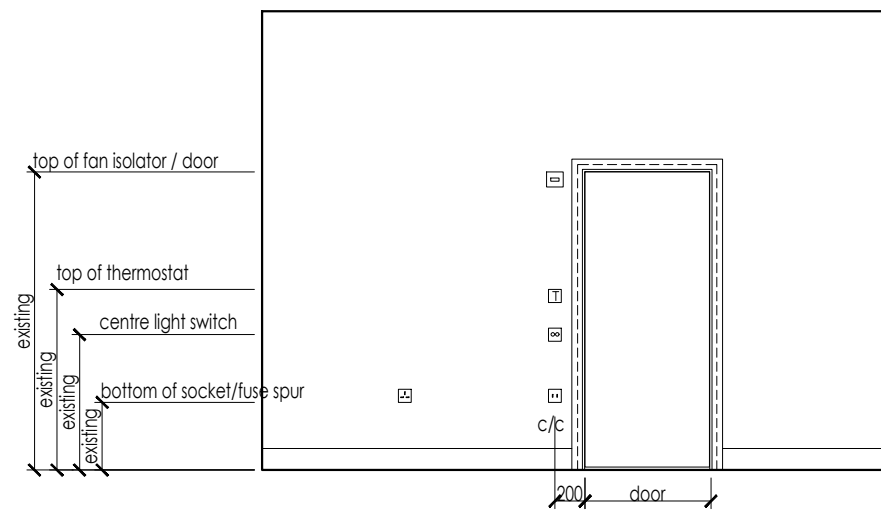

# 2

TYPICAL MOUNTING HEIGHTS  
SCALE 1:50

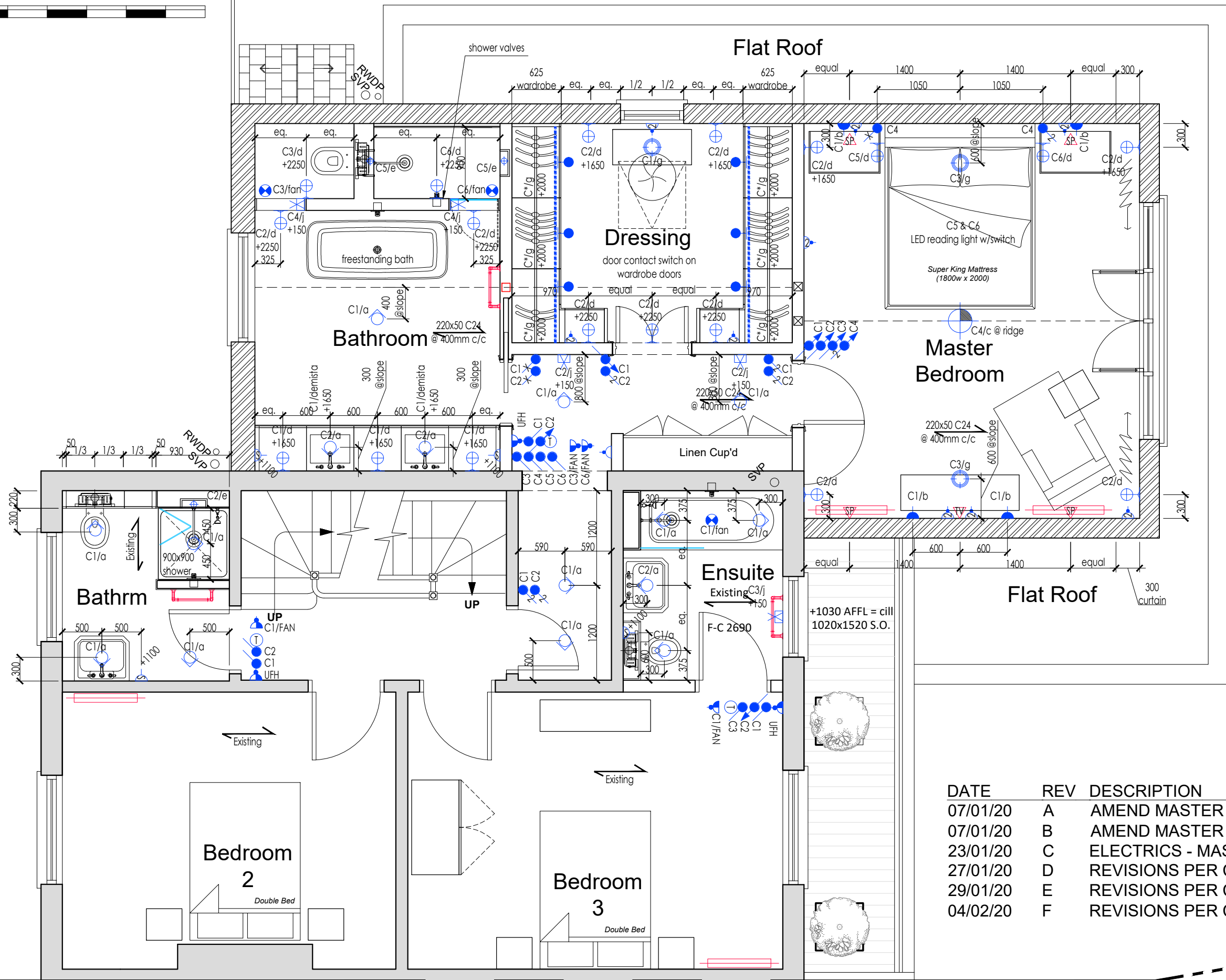
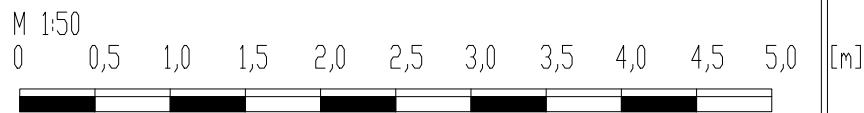

DATE	REV	DESCRIPTION
07/01/20	A	AMEND MASTER BEDRM DIMENSIONS
07/01/20	B	AMEND MASTER DRESSING/ENSUITE
23/01/20	C	ELECTRICS - MASTER SUITE
27/01/20	D	REVISIONS PER CLIENT MEETING
29/01/20	E	REVISIONS PER CLIENT MEETING
04/02/20	F	REVISIONS PER CLIENT MEETING

FIRST FLOOR  
 07 Jan 2020  
 1:50 @A3 / 1:100 @A4

Adjoining property  
 No 2

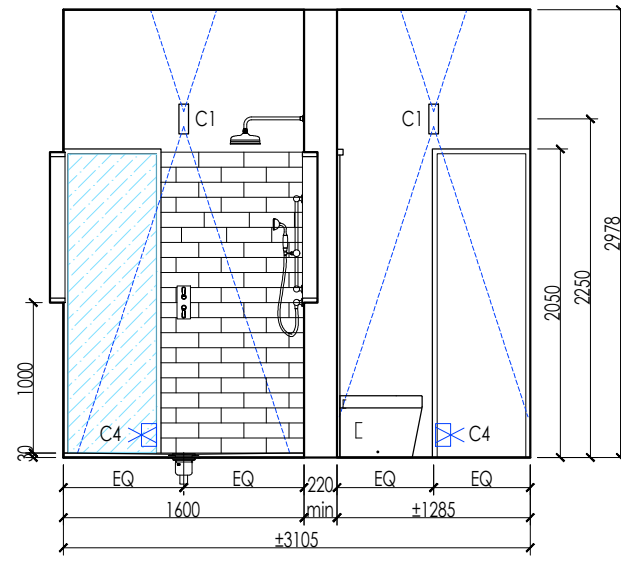

ELEVATION / SECTION @ SHOWER / TOILET

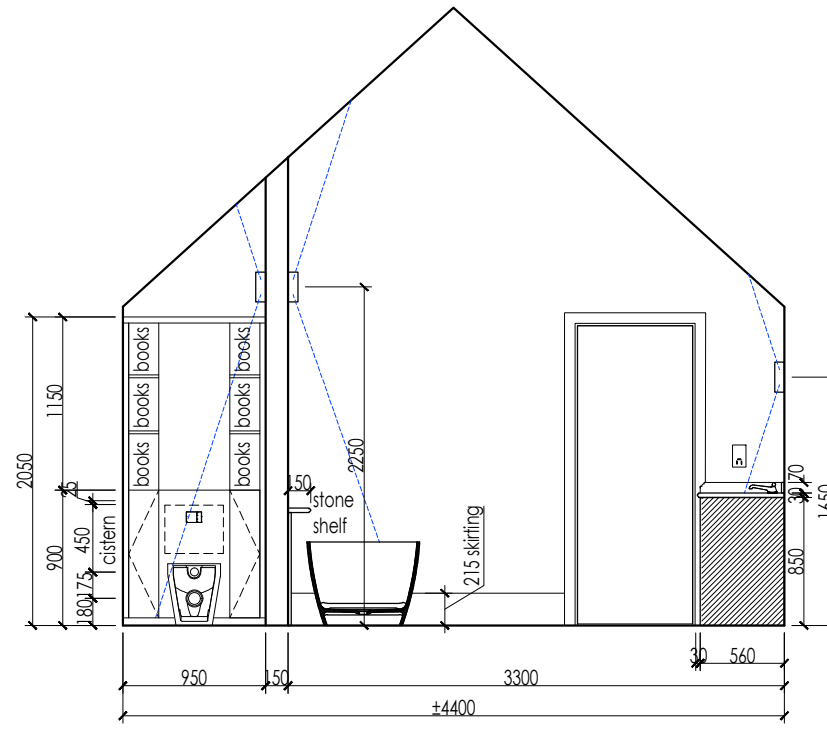

ELEVATION / SECTION @ CISTERN UNIT

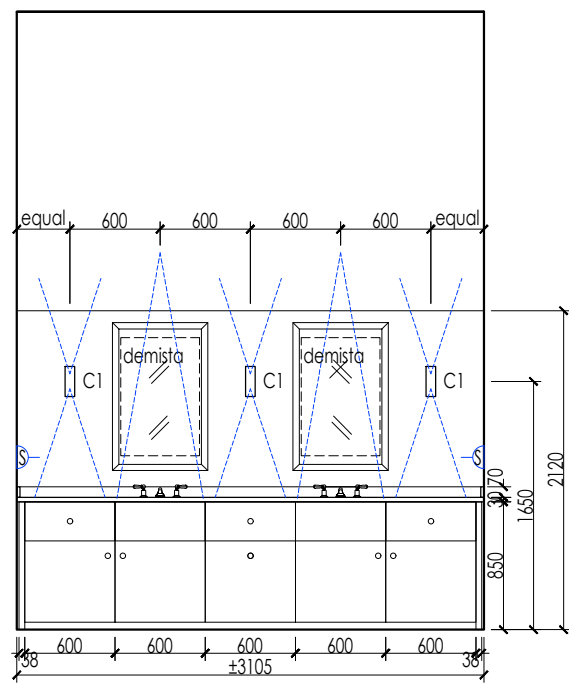

ELEVATION - VANITY UNIT WALL

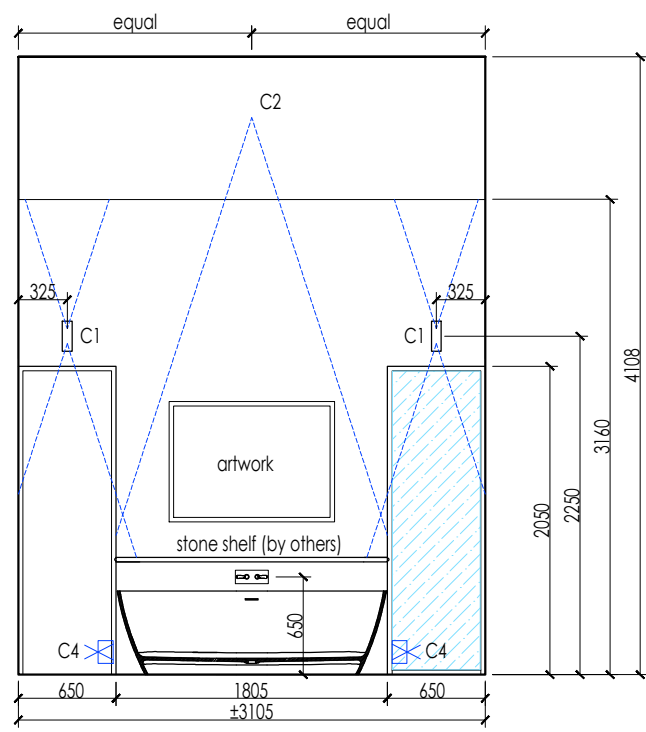

ELEVATION - BATH WALL

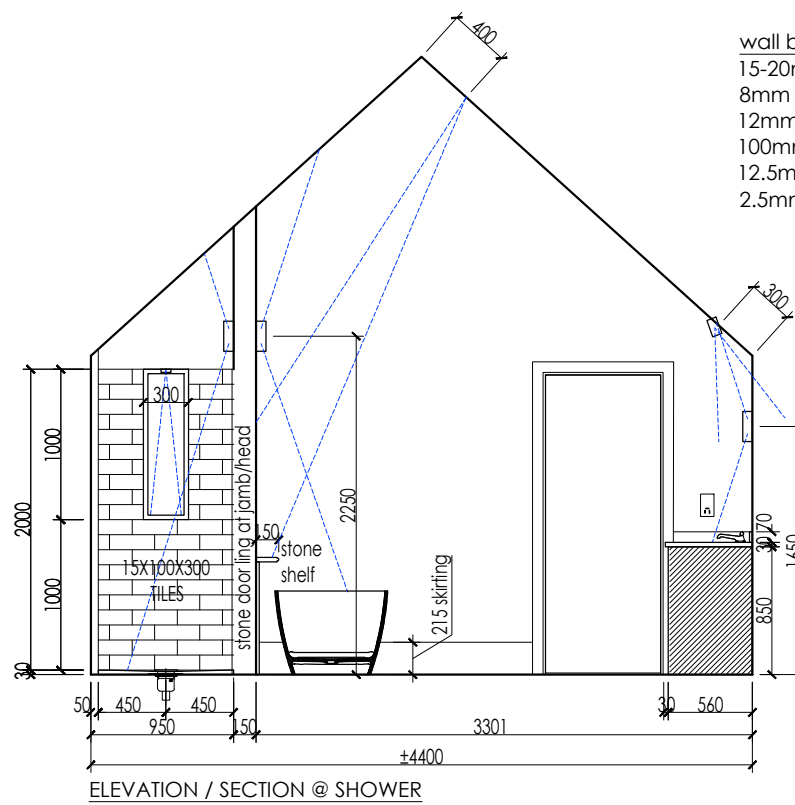

ELEVATION / SECTION @ SHOWER

wall build-up (shower/bath)  
 15-20mm stone tile (50kg/m<sup>2</sup>)  
 8mm adhesive  
 12mm cement backer board  
 100mm partition  
 12.5mm MR plasterboard  
 2.5mm plaster skim

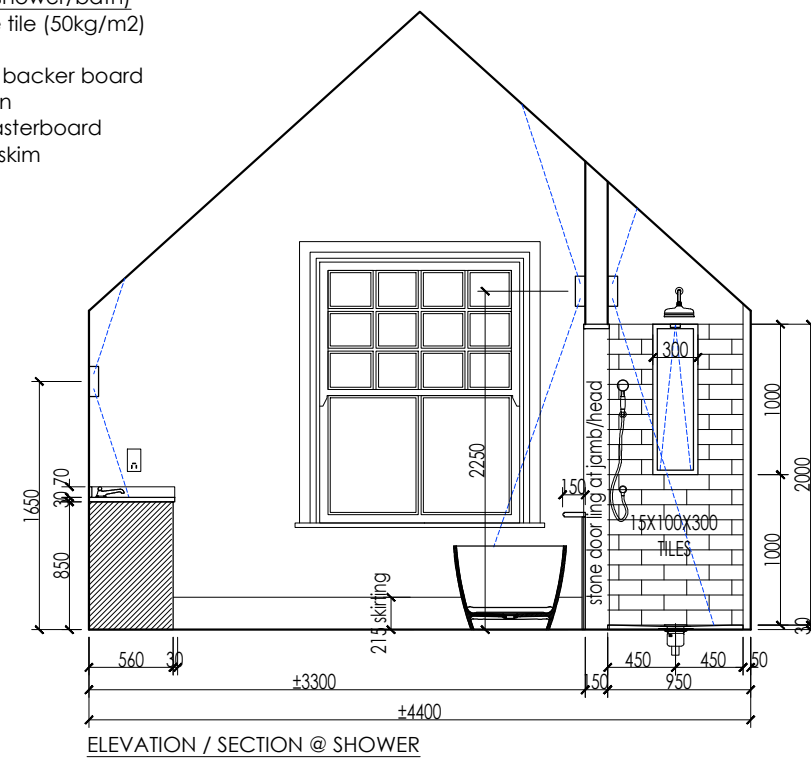

ELEVATION / SECTION @ SHOWER

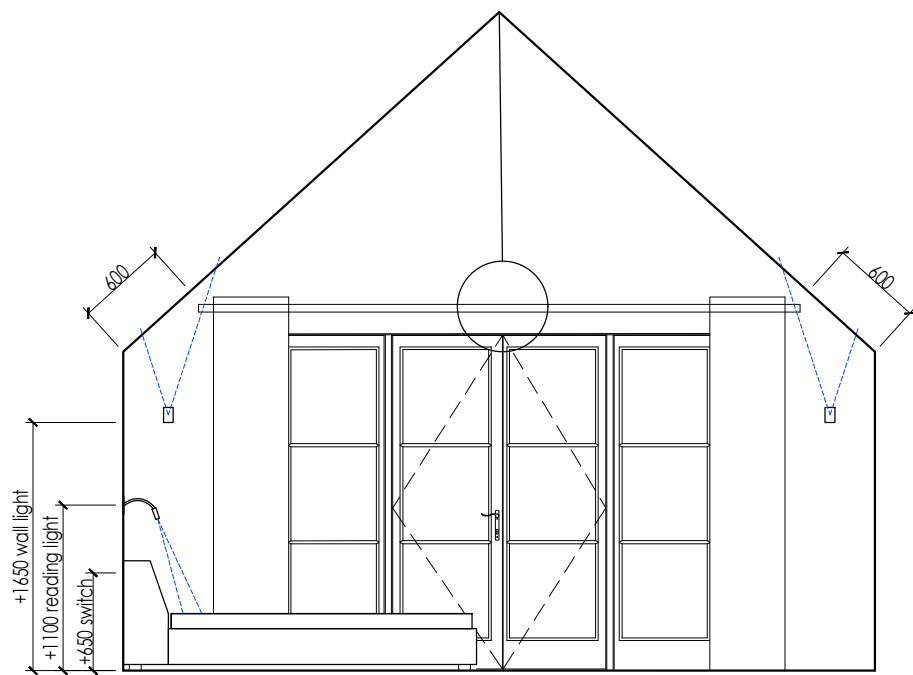

ELEVATION / SECTION @ MASTER BEDROOM

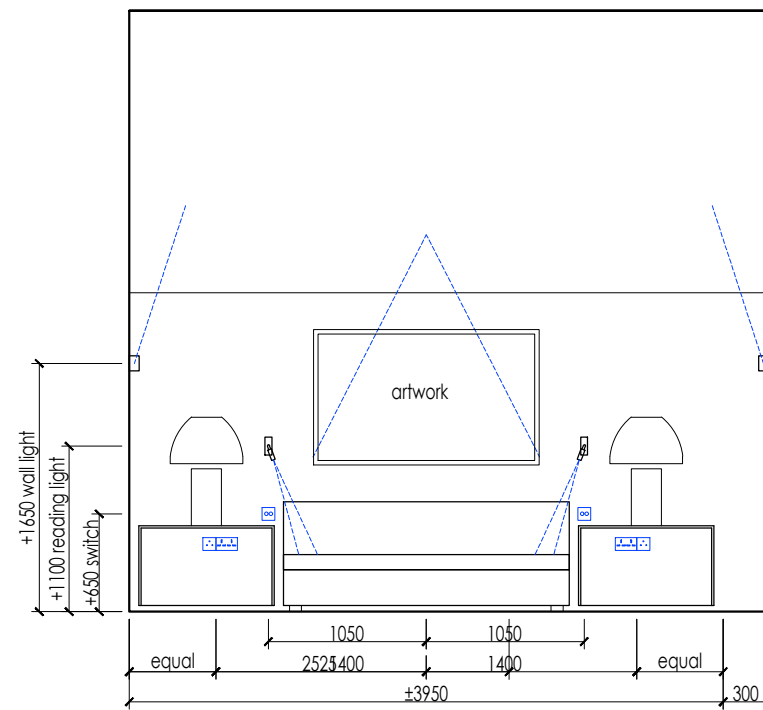

ELEVATION @ MASTER BEDROOM HEADBOARD

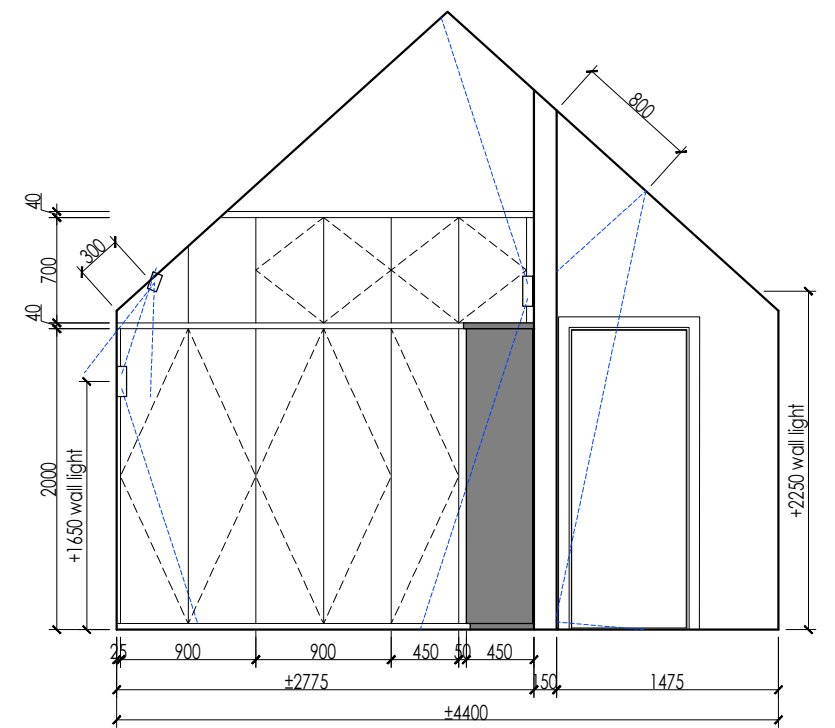

ELEVATION / SECTION @ DRESSING ROOM / CORRIDOR

ELEVATIONS - MASTER BEDROOM  
 23 Jan 2020  
 1:50 @A3 / 1:100 @A4

DATE	REV	DESCRIPTION
27/01/20	A	REVISIONS PER CLIENT MEETING
30/01/20	B	REVISIONS PER CLIENT PHONE CALL

M 1:50  
 0 0,5 1,0 1,5 2,0 2,5 3,0 3,5 4,0 4,5 5,0 [m]

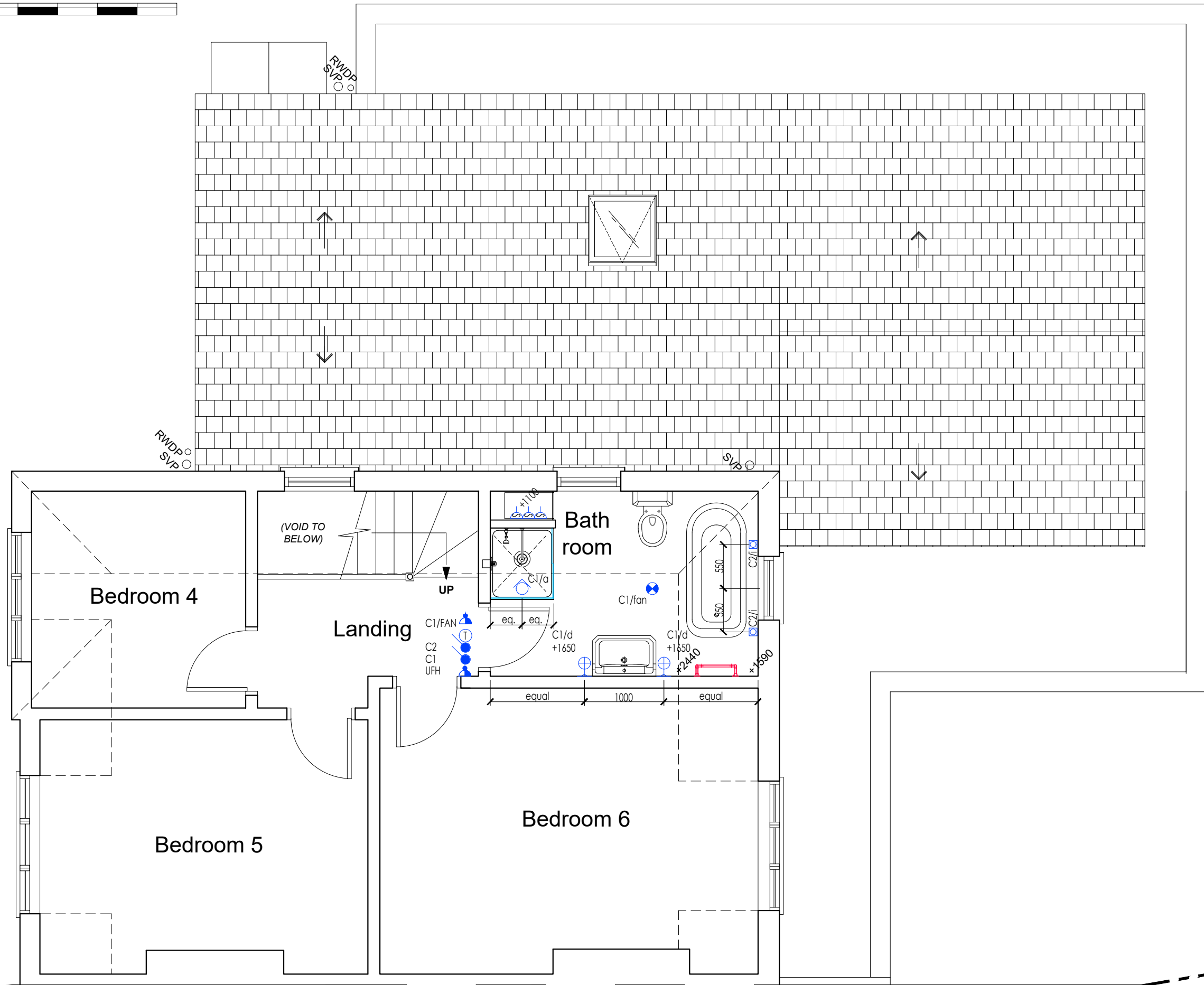

SECOND FLOOR  
 30 Jan 2020  
 1:50 @A3 / 1:100 @A4

Adjoining property  
 No 2

DATE	REV	DESCRIPTION
04/02/20	A	REVISIONS PER CLIENT MEETING



No 4

No 2

Driveway Access  
to Tennis Courts

FRONT ELEVATION (2)  
07 Jan 2020  
1:50 @A3 / 1:100 @A4



3000  
300  
300  
600  
2630

New painted timber side entrance door with arched fan light above in style to match existing at front of house, with lightweight timber door canopy

SIDE ELEVATION (2)  
07 Jan 2020  
1:50 @A3 / 1:100 @A4

DATE	REV	DESCRIPTION
07/01/20	A	AMEND STRUCTURAL OPENING DIMS
04/02/20	B	DOOR-CANOPY CENTRED OVER DOOR



No 2

No 4

Driveway  
to Tenr

REAR ELEVATION  
07 Jan 2020  
1:50 @A3 / 1:100 @A4

DATE	REV	DESCRIPTION
07/01/20	A	AMEND STRUCTURAL OPENING DIMS
24/01/20	B	ADD RAILINGS, AMEND CRITAL DIMS