

S36001

2nd call of 2

Notes for Measure

Estimator: Chris

Mr Malcolm Taylor, 40 Granard Avenue

Date of Measure: Mon, 19 Jan 26

At: 2:15pm if poss (2-3)

Site Address:

40 Granard Avenue
Putney

LONDON

SW15 6HJ

Customer Address:

40 Granard Avenue
Putney
LONDON

SW15 6HJ

CONTACT: As customer details

Mobile	Home	Office
07771-931434		

Email: mcvtaylor@icloud.com

Areas to be done and Description of Measure

Lounge, 2 x SL - had rest fitted 5-6 year ago, nice old man

Set 21 Jan

Instructions and Estimators comments

Westex Ultima - CHS - try to take folder from Fulham if Chris has it. Park in Driveway

Must Read!

.Nice Guy Chris Saw

Office Ref: S36001

Mr Malcolm Taylor, 40 Granard Avenue

Date of Measure Mon, 19 Jan 26

At 2:15pm if poss (2-3)

Floor: Wood / Concrete / other _____

S/edge: Wood/Concrete/No pin/existing (if existing, allow ___ sticks to supplement where necessary)

Sticking Req'd: Yes/No Type: Fastset/Other

Underlay: Re-use Existing / New required

Type: 42oz Felt / Fomalux / PU Foam / Luxury PU Foam / LowTog / Durafit

Doorbars: Alloy / Satin Ali / Polished Ali / Anod / Solid Brass / Chrome / Nisheen
Seam/Wood/T/Holds: colour _____

Door Clearance: OK / Low (advise on quote)

Uplift: No / Yes (if "Yes" - what type?) uplift/roll & tape
Leave outside.

Furniture: No/Yes (if YES, please specify the following) - 1 man / 2 men (Fitter to get paid) £ _____ total/per room X5 + Piano.

Parking Cost: Free / £ _____ per hour Park on Driveway!

Parking Restrictions: (type) / £ _____

Congestion Zone: No / Yes

Access: Easy / Hard / 2 men req'd / 1/2 floor?

Runners: Whipping / Binding (if binding, specify type)

Tape size: 1 1/2" / 2" / 3" / 5"

Style: Top taping / Side binding

Stairrods: Type _____ Nr _____ Size _____

Must Read: .Nice Guy Chris Saw

Job No:

Malcolm Taylor

Address:

S36001

Tel:

Sheet:

of:

0 → 366

366

Diner

660

366

Large 630

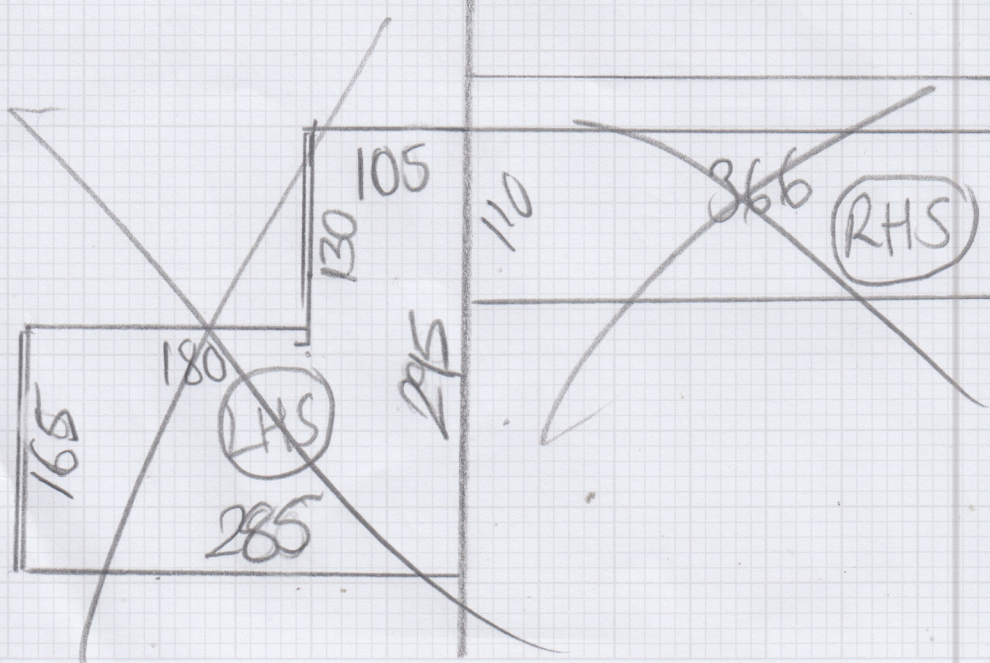

2 @ 50 x 87
1/2 Load @ 125 x 237
11 @ 50 x 87 - 87

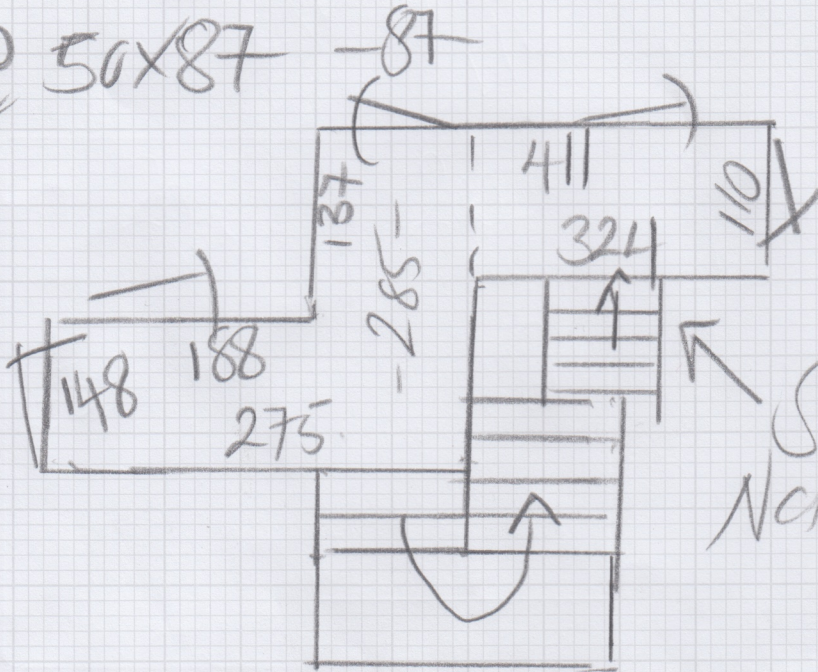

← 599 →

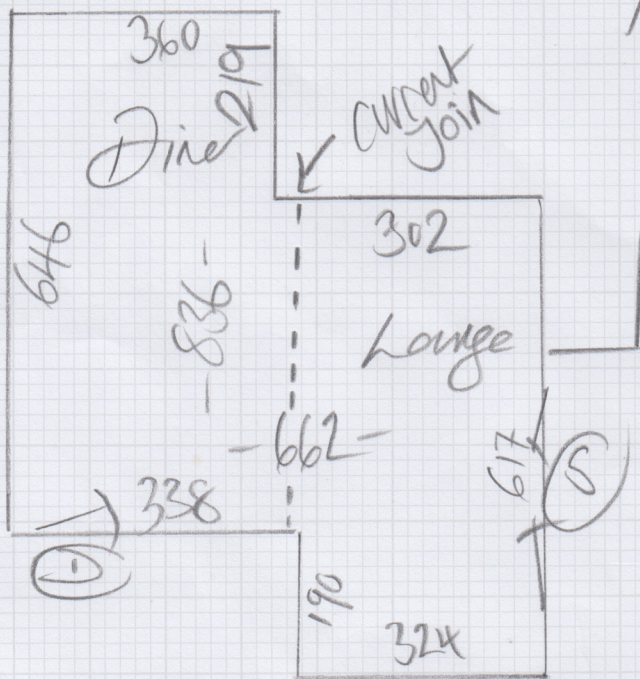

Take up 11 x
Rods +
S/L of /
1/1 way
& leave
outside
for carid.