

R16596
 HARDWICK
 31 LAMBTON RD
 SW20.

TOP FLOOR (NEW)

1 1.

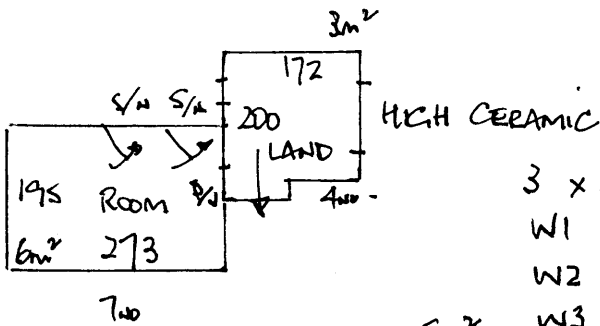

- 5m²
- 3 x 43 x 73
 - W1 58 x 81
 - W2 65 x 100
 - W3 70 x 70
 - W4 60 x 83
 - W5 65 x 102
 - W6 62 x 70
 - 2 x 43 x 72
 - B/N 30 x 85
 - 20 x 95

NEW (GRIPPER ROAD)
 15m²

FIRST FLOOR

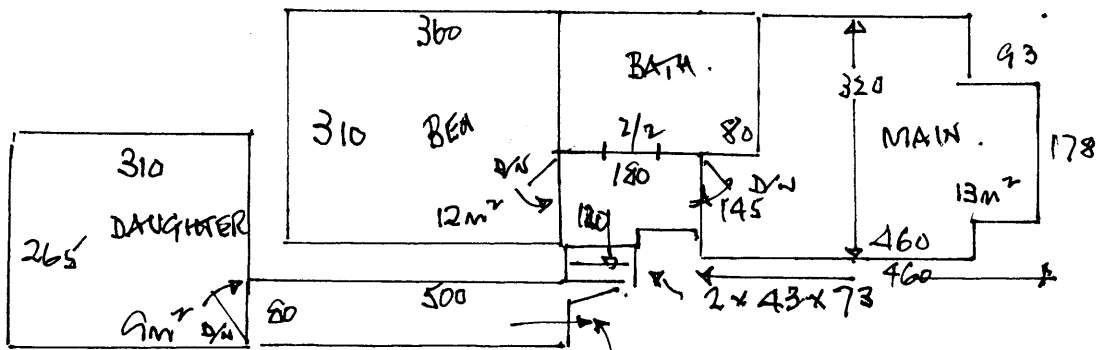

- 5m²
- 50 x 80
 - 16 x 90
 - W7 44 x 80
 - W8 60 x 95
 - W9 65 x 110
 - W10 65 x 75
 - W11 50 x 73
 - 4 x 44 x 73
 - 1 x B/N

- u/lav 58m²
- d/n 4no
- s/n 3no
- z/z 2no
- qr 27no.
- u/d 45m²
- fuln 3no.

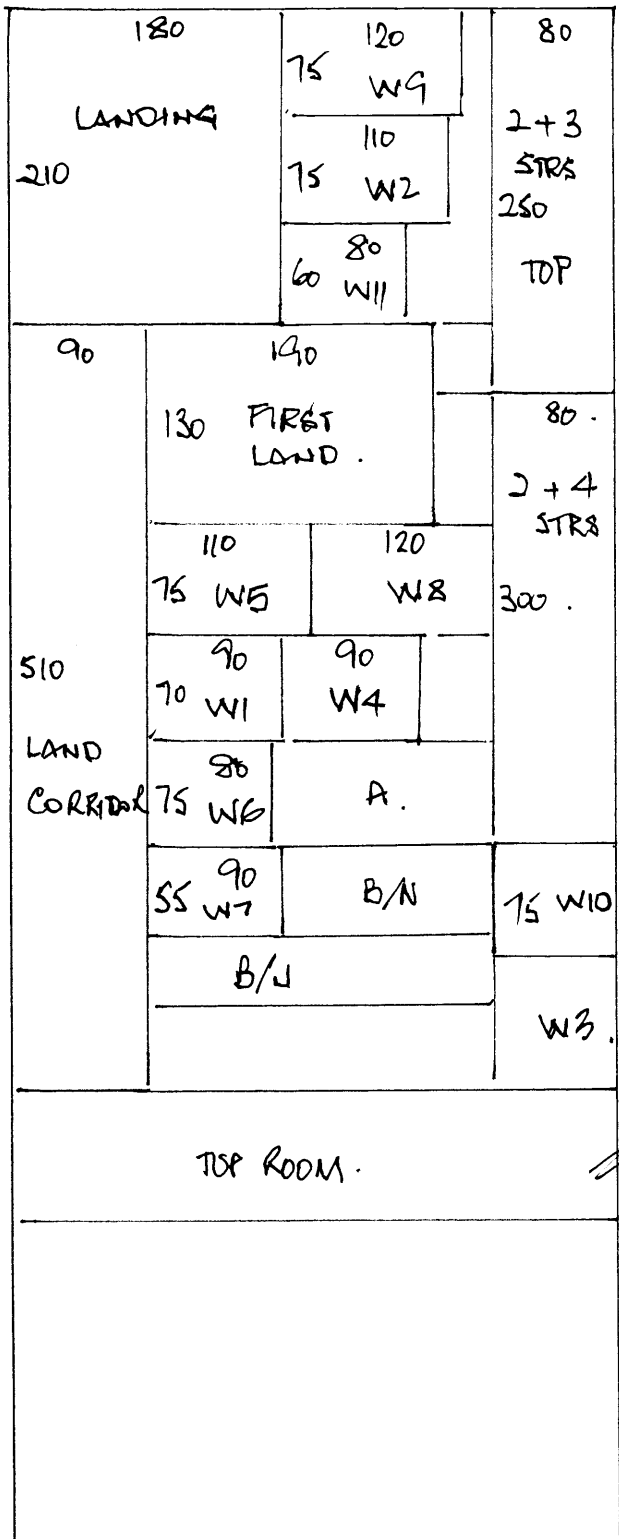

R16596
HARDWICK
31 LAMBTON RD
SW20

1 1

SUPREME STRIP

CFP. $7.20 \times 4.00 = 28.80m^2$
 TOP $\rightarrow 2.05 \times 4.00 = 8.20m^2$

TWERTON

330	x	4.00	(BEN)	} 44.80m ²
470	x	"	(MAIN)	
320	x	"	(D'GARRE)	
205	x	"	(TOP)	
				8.20m ²

53m²