

R16590  
 KEBBLE  
 65 BUCKLEIGH AVE  
 SW20.

1 2.

FIRST FLOOR.

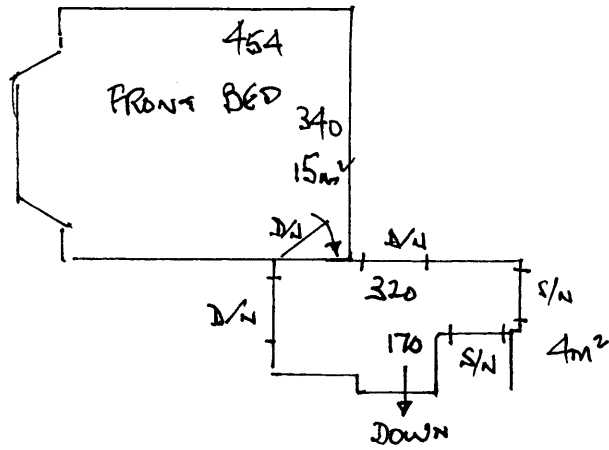

GRIPPER R/O/D.

U/W 24m².  
 GR. 35m².  
 D/W 3m²  
 S/W 2m²

- I x 42 x 78
  - W1 61 x 89
  - W2 67 x 109
  - W3 66 x 76
  - 8 x 42 x 78
  - B/W 35 x 105
  - 20 x 115
- 5m²

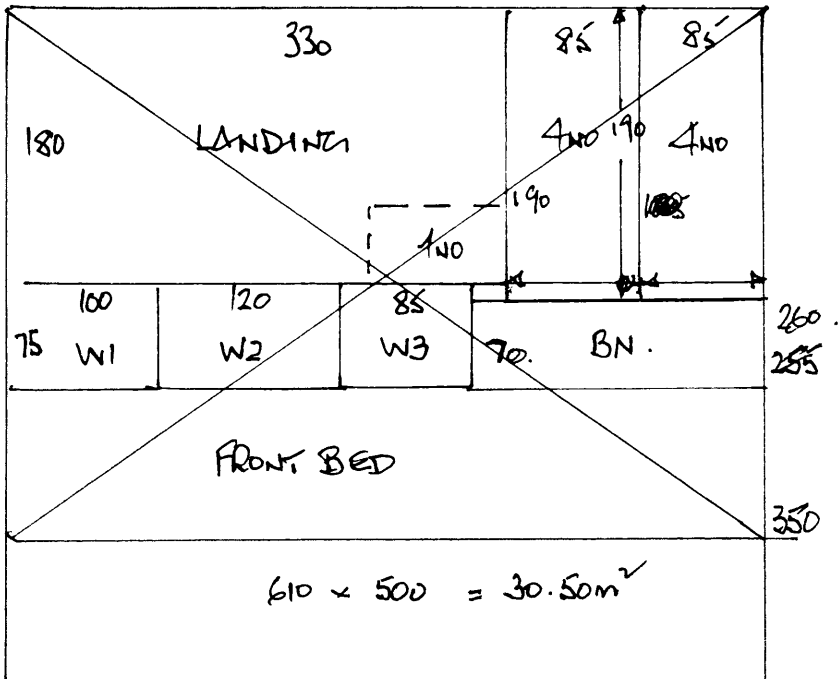

R16590.  
 KEBBLE  
 65 BUCKLEIGH AVE  
 SW20.

2 2

THIS PLAN

