

R16022
 LAMPARD
 1 BATHURST AVE
 SW19.

FIRST FLOOR.

UPLIFT & DISPOSE
 EXISTING GRIPPER.

D/N x 3
 2/2 x 1.

1 2.

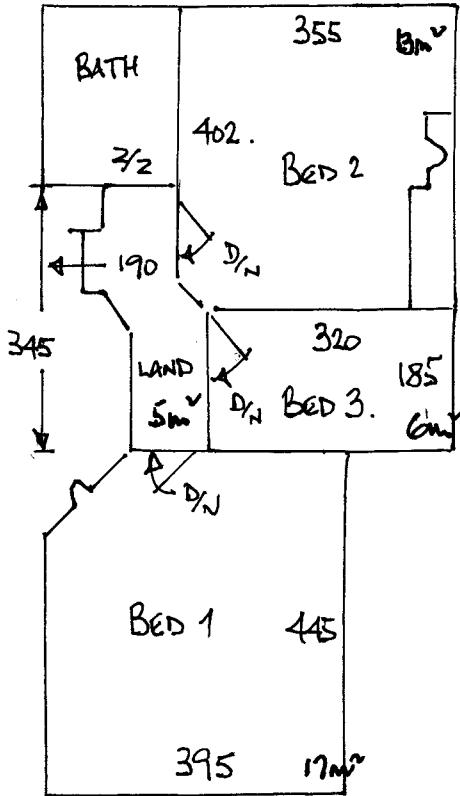

STAIRS.

- 1/4 L 100 x 85
- 5 x 40 x 80
- W1 60 x 90 5m²
- W2 70 x 110
- W3 65 x 77
- 3 x 40 x 80.
- 1 x BN.

GROUND FLOOR

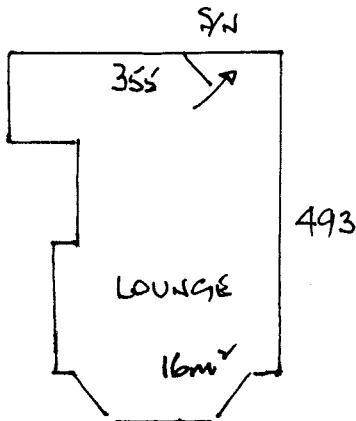

* UPLIFT & DISPOSE CARPET ONLY *.
 REUSE EXISTING U/LAY + GRIPPER
 S/N x 1no.

U/LAY 46m²
 D/N 3
 2/2 1.
 S/N 1.

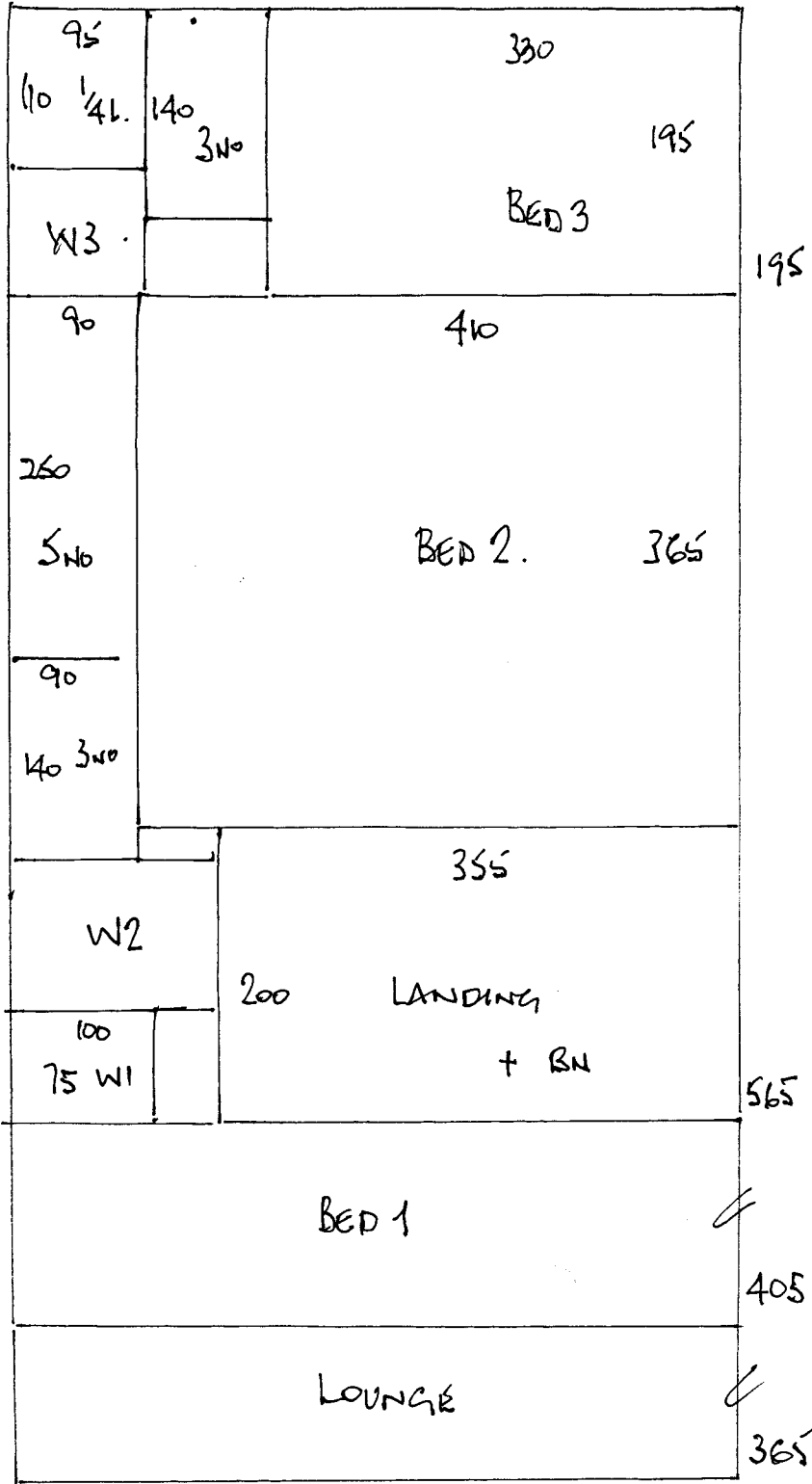

R16022
 LAMPARD
 1 BATHURST RD
 SW19.

0 2.

CURS :

$$\begin{array}{r}
 195 \times 500 \\
 565 \times \text{"} \\
 405 \times \text{"} \\
 365 \times \text{"} \\
 \hline
 \cancel{19.55} \times 500 = \\
 15.30 \qquad \qquad 76.50m^2
 \end{array}$$