

Breakdown no. R001 P055	RAC Patrol name and call sign TREV-2915	Reg no. MRS6 CPT	Exact Mileage 81972
-----------------------------------	---	----------------------------	-------------------------------

Description of all work carried out, suspected diagnosis, parts replaced and any other comments
Non Start - Battery @ 12.2 volts. - Carried out Boost Start Procedure - Starter ~~is~~ turns for short period then stops -
Suspect either poor connections on battery positive - "fuse box" - or Starter Motor. - May Req battery soon, Charging @ 14volts.

Suspected Diagnosis - Verify all diagnosis with your preferred repairer prior to any work being completed or ordering any parts

Vehicle Condition **S = Scratch M = Missing B = Broken D = Dent**

- Dirty
- Day
- Night
- Dry
- Wet
- Motorway

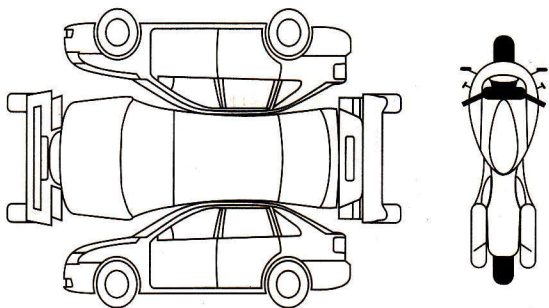

Recovery Address
Needs further investigation.
Engine Started after 2/3 attempts. Messing with positive lead on battery.

The RAC Patrol has clearly explained the details and I accept:-

- The vehicle battery has failed and requires replacement. I have declined an RAC battery and understand that the electrical system requires further testing at my preferred repairer.
- That disconnecting the jump leads whilst the engine is running risks permanently damaging the vehicle electrical / electronic systems. RAC will not be liable for the resultant damage.
- The vehicle is considered not safe to drive.
- The vehicle has sustained damage prior to RAC attendance.
- Force will be required, which may result in damage to the vehicle. RAC will not be liable for the resultant damage.
- My engine overheated prior to RAC attendance, which may have compromised the head gasket or internal components.
- A temporary repair has been carried out which requires a permanent workshop repair at the earliest opportunity.
- I need to arrange for the wheel nuts and / or other safety critical fixings to be retightened as per manufacturer's instructions. RAC recommend that this should be done prior to the next use of the vehicle, or within 100 miles.
- I have been given instructions on how to control my vehicle during towing. If my vehicle is damaged as a result of not following the instructions, I agree that RAC will not be liable for any loss, damage or cost incurred.

By signing this form, I acknowledge that:-

- I have read and understand the instructions on this form.
- All effects removed from the vehicle have been returned to me or refitted.
- If a condemned battery is not replaced, we may provide further assistance for a battery related fault but in this case a separate charge will be payable by debit / credit card before assistance can be arranged.
- The diagnosis given by the RAC Patrol requires confirmation by a qualified technician in a workshop environment prior to any further work or parts replacement is considered.
- The vehicle condition stated in this report is a true record of the vehicle condition prior to the recovery / tow.

Print Name **R. GLOUGH**

Customer Signature *[Signature]*

Print Name of 3rd Party

Signature of 3rd Party