

Gradus Grip

(sheet 1 of 3) 1st December 2015

Site conditions vary - to ensure that this product is suitable and to confirm that this data sheet is current please contact our Technical Support department.

Introduction

Gradus Grip is a rapid curing flexible adhesive with excellent gap filling properties that is suitable for bonding Gradus stair edgings to most solid surfaces in internal and external environments. When fixing to suitable solid substrates mechanical fixings are not required.

Surface Preparation

Prior to application ensure that all surfaces are smooth, sound, clean and free of laitance, dust and contamination. If a levelling compound or repair mortar is required ensure that the manufacturer's instructions are followed to ensure the material is ready to provide a strong surface. The product to be adhered should also be clean and free from contamination such as oil, grease etc that may impair adhesion.

Suitable Substrates:*	Non-suitable Substrates:
Electroplated Metal	Weak, friable, dusty concrete/ screed etc
Concrete / Powerfloat	Asphalt / Bitumen
Floor Smoothing Compounds	Polyethylene / Polypropylene
Repair Mortars (Cement and Epoxy)	Oil / grease contaminated surfaces
Terrazzo / Marble / Ceramics / Engineering Brick	
Fibre Glass	
Plywood / OSB / Chipboard / MDF / Wood	
Plaster / Plaster Board	
Paint/ Epoxy / PU Coatings and Screeds	

*This table is a guide only and you may encounter different substrates and other factors that will affect the suitability such as undulations, flaking paint or weak plaster.

Application

The adhesive should be applied in straight lines** (parallel to the stair edging) by means of a suitable applicator gun. Fix nozzle and cut the aperture to the required width dependant on application. Apply the adhesive to one surface only and then press the two surfaces together within the open time of the adhesive. The high initial grab and rapid strength gain will generally mean that no mechanical fixings are required.

Absorbent Surfaces

Single channel stair edgings - apply the adhesive to the underside of the stair edging in 5mm wide linear beads beginning 5mm in from the back edge of the profile. A second bead should be applied in the centre of the profile. See Fig.1

Double channel stair edgings (less than 110mm tread size) - As per single channel stair edgings with the addition of a third bead of adhesive approximately 10mm from the front edge. See Fig.2

Multi-channel stair edgings / double channel stair edgings (greater than 110mm tread size) - please contact Gradus for further details.

Fig.1

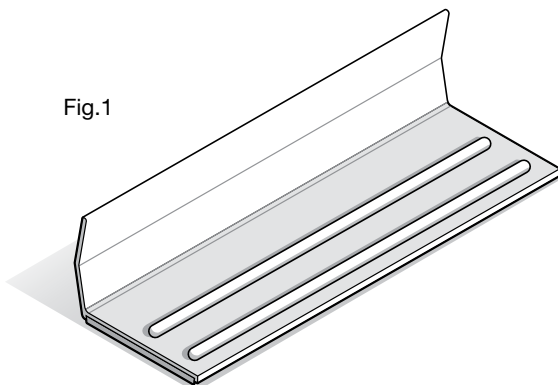
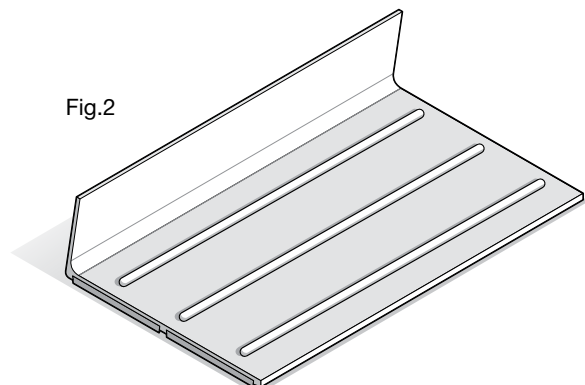

Fig.2



Gradus Grip

(sheet 2 of 3) 1st December 2015

Place the profile so that the leading edge is overlapping the edge of the step and press down whilst sliding the profile into place. Press down firmly to ensure a full bond.

Cure Time – Allow approximately 1 hour after fixing before opening the area to traffic. The installation should be checked to ensure the bond is sufficiently secure before opening the area. For beads greater than 5mm in thickness the cure time will be extended.

Note – for stair edgings that are castellated it is recommended to increase the thickness of the bead(s) up to 8mm to ensure full adhesion and allow additional time for the adhesive to cure.

Non-Absorbent Surfaces

When bonding stair edgings to metal substrates or other suitably smooth non-absorbent surfaces first dampen or mist the area with water. **Do not** leave standing water on the surface. In addition mist the stair edging with water before applying adhesive as described below. This method will accelerate the cure time of the adhesive and allow the area to be opened after a minimum of 2 hours, however the bond strength should be checked to ensure it is safe to open.

Single channel stair edgings - Apply the adhesive to the underside of the stair edging in 3mm wide linear beads beginning 5mm in from the back edge of the profile. A second bead should be applied 10mm from the front edge of the profile and a third bead in the centre of the profile. See Fig.3

Double channel stair edgings (less than 110mm tread size) – Apply the adhesive to the underside of the stair edging in 3mm wide linear beads beginning 5mm in from the back edge of the profile. A second bead should be applied 10mm from the front edge of the profile with an additional 2 beads of adhesive applied equidistant between the inner and outer beads. See Fig.4

Multi-channel stair edgings / double channel stair edgings (greater than 110mm tread size) – Please contact Gradus for further details.

Fig.3

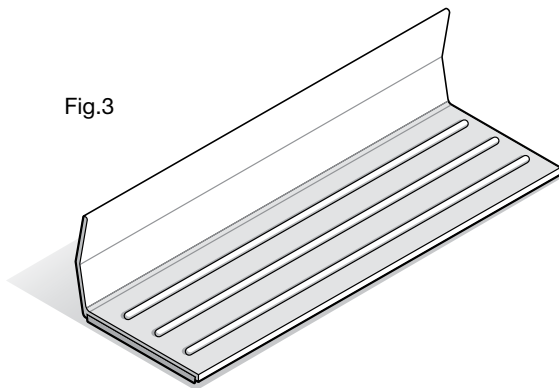
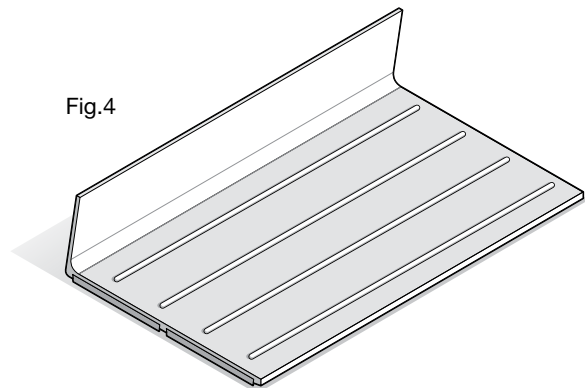

Fig.4



Place the stair edging so that the leading edge is overlapping the edge of the step and press down whilst sliding the profile into place. Press down firmly to ensure a full bond.

Cure Time – Allow a minimum of 2 hours after fixing before opening the area to traffic. The installation should be checked to ensure the bond is sufficiently secure before opening the area. For beads greater than 5mm in thickness or when bonding non-absorbent surfaces that are not suitably dampened the cure time will be extended.

Note – for stair edgings that are castellated it is recommended to increase the thickness of the bead(s) up to 8mm to ensure full adhesion and allow additional time for the adhesive to cure. (typically 24 hours).

Note – for further installation instructions, refer to each products individual installation guidelines for suitability and application.

Gradus Grip

(sheet 3 of 3) 1st December 2015

Cleaning

Remove any excess wet adhesive from surfaces with a proprietary wipe

Precautions

Temperature – adhesive must be applied onto substrates which are above 5°C and remain so whilst curing takes place.

****Do not snake / zig zag the adhesive beads, as this can significantly reduce bond strength** – always apply in straight (linear) beads.

Thicker beads take longer to cure, however always ensure sufficient material is applied relative to the installation being undertaken.

Stair edgings must not be disturbed or moved during the curing period of the adhesive.

Where stair edgings are installed without additional mechanical fixing, always check the bond is secure before opening the area to traffic.

Where ramp back stair edgings are installed on top of floorcoverings suitable mechanical fixings should also be used in addition to Gradus Grip.

Note – Gradus Grip is not suitable for use with the following profiles – CXT range, ELA91150, ELA93150, R75XT11, R75XT51, R95XT11, R95XT51, RXT1218L, RNT1218L and ATD121L

Technical Information

Colour	White
Consistency	Paste
Open Time @ 23°C and 50% RH	Maximum 10 minutes

Coverage

Tube Size	Bead Diameter	Coverage Per Tube
290ml	3mm	38 linear metres
290ml	5mm	14 linear metres
290ml	8mm	5 linear metres

Note – Coverage rates will depend on the condition and absorbency of the substrate

Packages

290ml composite cartridge
12 cartridges per carton

Standards

Conditions must comply with the relevant British Standards

Tools

Heavy duty applicator gun (preferably with an 18:1 trigger ratio)

Storage & Shelf Life

Store between 5°C and 25°C. Protect from frost.
12 month shelf life in unopened cartridges stored under good conditions.