

mrcarpet
 Job No: F27997
 Name: GREEN
 Address: Flat 3 GK
 225 Limerbrook
 Tel: SWIS 2PX
 Sheet: 01

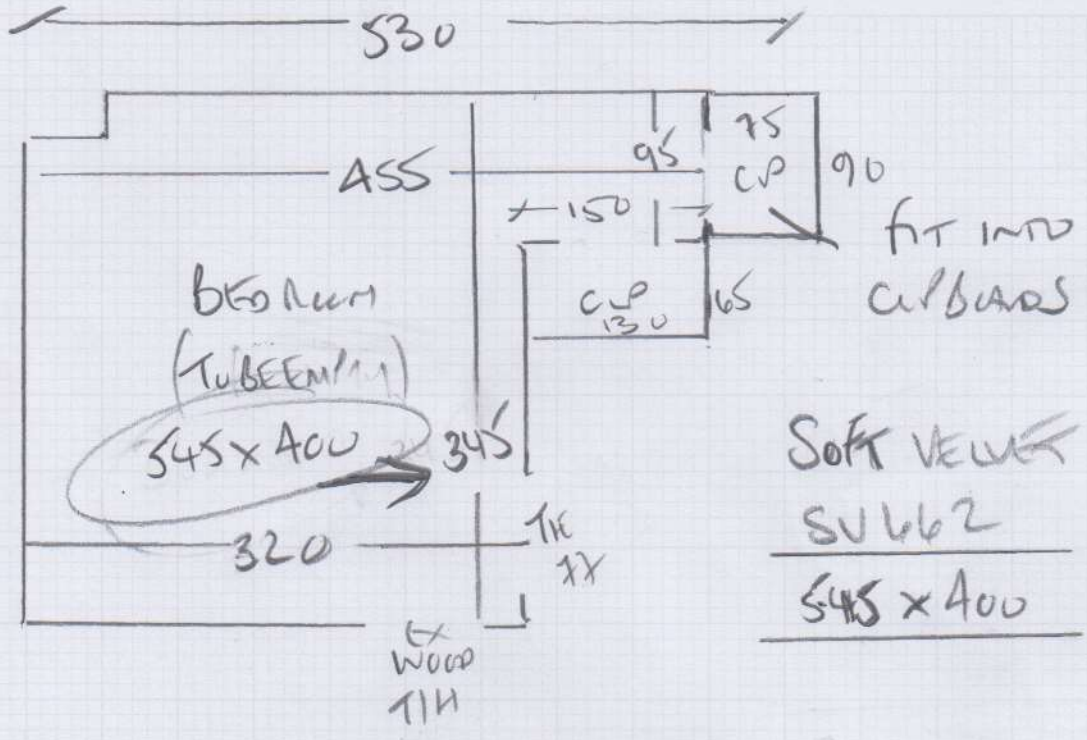

SOFT VELVET
 SU 662
 545 x 400

CONCRETE FLOOR
 EXISTING STAIRS
 ALL TILES TO LOW-SURFACE BATHROOM

3
 18m

F27997

4th call of 4

Notes for Measure

Estimator: Colin

Charlie Green, Flat 3, Ground Floor Flat

2nd

Date of Measure: Thu, 11 Mar 21

At: TBC

9:30am - 10:30am

Site Address:

Flat 3, Ground Floor Flat
225 Putney Bridge Road

LONDON SW15 2PX

Customer Address:

Flat 3, Ground Floor Flat
225 Putney Bridge Road
LONDON

SW15 2PX

CONTACT: As customer details

Mobile	Home	Office
07773-070573		

Email: charlieincegreen@dexters.co.uk

Areas to be done and Description of Measure

Measure bedroom

Instructions and Estimators comments

Remnant or clearance to select

Must Read!

Please call tenant Laura 07508-742680 for access

Office Ref: F27997

Charlie Green, Flat 3, Ground Floor Flat

Date of Measure Thu, 11 Mar 21

At TBC

Floor: Wood / Concrete / other _____

S/edge: Wood/Concrete/No pin/existing (if existing, allow ___ sticks to supplement where necessary)

Sticking Req'd: Yes/No Type: Fastset/Other

Underlay: Re-use Existing / New required

Type: 42oz Felt / Fomalux / PU Foam / Luxury PU Foam / LowTog / Durafit

Doorbars: To EN-SURE DAM
 Alloy / Satin Ali / Polished Ali / Anod / Solid Brass / Chrome / Nisheen
 Seam/Wood/T/Holds: colour EXISTING WOOD 714 AS BEDROOM DOORWAY

Door Clearance: OK Low (advise on quote)

Uplift: No / Yes (if "Yes" - what type?) felt back on PU foam + stone

Furniture: No/Yes (if YES, please specify the following) - 1 man / 2 men (Fitter to get paid) £ 25 total/per room

Parking Cost: Free / £ 300 per hour

Parking Restrictions: (type) / £ £150

Congestion Zone: No / Yes

Access: Easy / Hard / 2 men req'd / Ground floor?

Runners: X Whipping / Binding (if binding, specify type)

Tape size: 1½" X 2" / 3" / 5"

Style: X Top taping / Side binding

Stairrods: Type X _____ Nr _____ Size _____

EXISTING TENANT
 LARA MAIL
 OUT BY 26/3/21

Must Read: Please call tenant Laura 07508-742680 for access

Office Ref: F27997