

2.30

4MTR

.85 1.50 3 STPS	.85 1.00 2 STPS	.75 1.10 W4	1.20 W2
	.50 1.50 1.50 STPS	.75 W1	1.20 W5
/ / / / / / / / / /		.85 W3	.90 W6 ^{.80}

Job No: F26432
Name: LEWIS
Address: 9 BEAULIER RD
W6 ONR
Tel:
Sheet: 1 OF 2

CUT FROM SPLIT DELIVERY
6-55 x 5MTR

MAYFAIR BOUCLE

The TOP FLOOR
 areas will be
 Changed

Temporary
 Carpet *

Top Floor

F26432

LEWIS

9 BENVENUE RD

W6 OVR

2 of 2
~~6 of 6~~

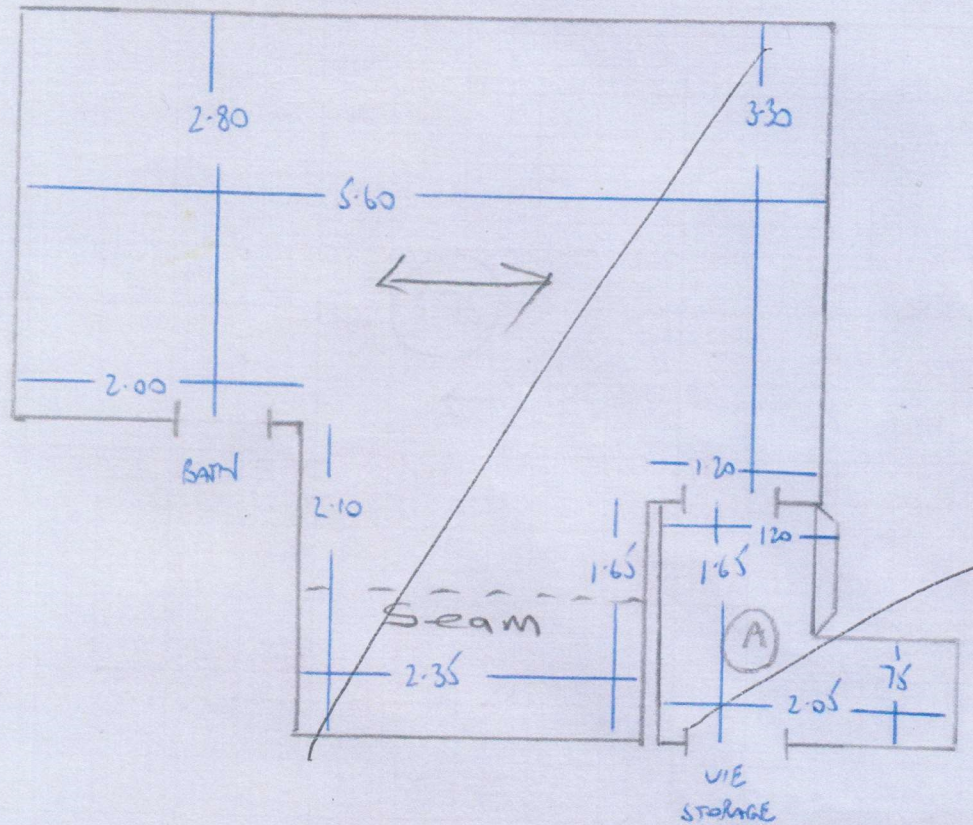

- 1 STR 72 ✓
- 1 w 85x60 ✓
- 2 w 108x66 ✓
- 3 w 75x67 ✓
- 5 STR 78
- 4 w 72x63 ✓
- 5 w 113x68 ✓
- 6 w 80x70 ✓