

Job No: R18268
 Name: CLARK
 Address: 9 THE GRANGE
 RAINESDALE
 SW20 9DN
 Tel:
 Sheet: 1 of 4

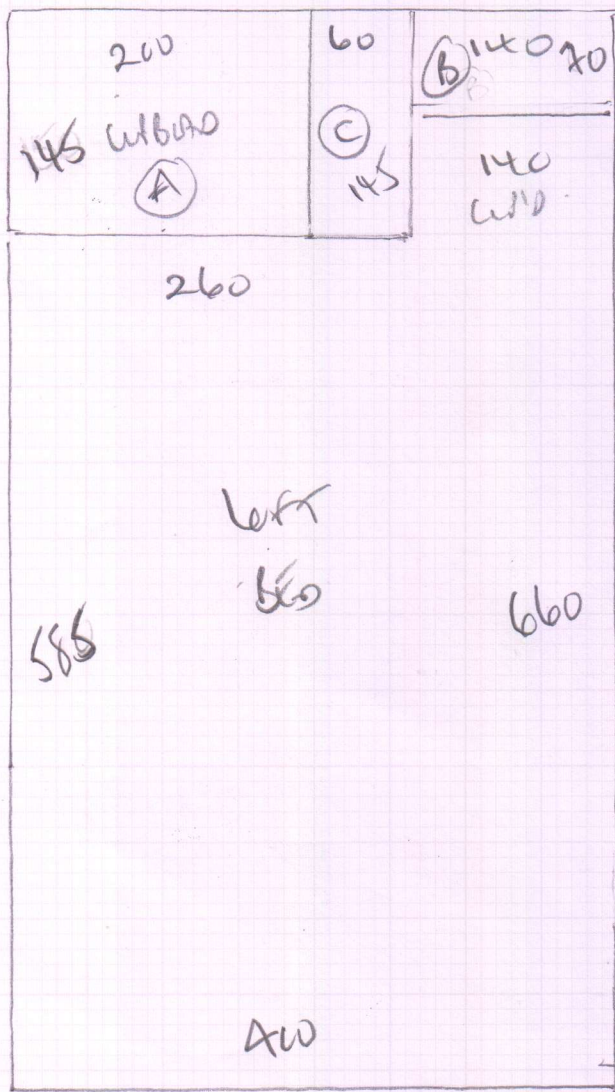

Left Bedroom
+ INTO W/BANDS

Subsiding Inst 'Sooz'
 Coral 635/31

Plan 730 x 400

29.20m²

Job No: R18268
 Name: CLARK
 Address: 9 THE FARWAY
 RAINES PARK
 SW20 9DN
 Tel:
 Sheet: 2 of 4

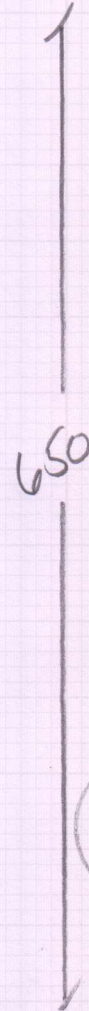
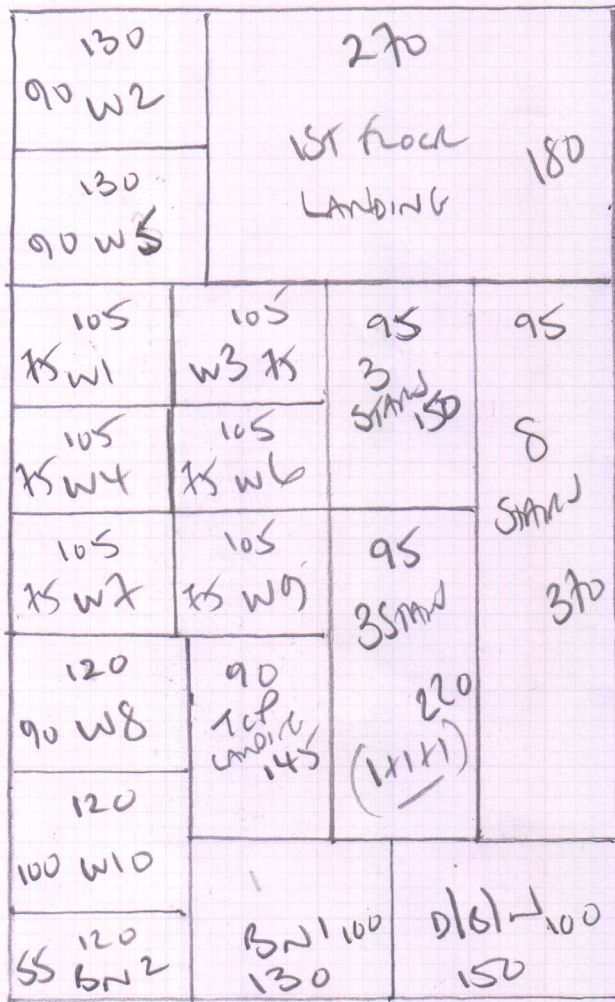

STAND + LANDINGS

1st floor to ground floor

MALEDONIA

Colour 609/37

RAW 650 x 400

26m²

Job No: R 18268
 Name: CLARK
 Address: 9 THE FAIRWAY
 RAINES LANE
 Tel: SW20 90W
 Sheet: 4 of 4

Toilet from Landmark

- Bn 1 65 x 120
- Bn 2 46 x 95

- ↑ IT 45 x 77
- WB 69 x 73
- WS 75 x 108
- W4 65 x 89

- ↑ 31
- 46 x 78
- WB 68 x 75
- W2 75 x 108
- W1 65 x 87

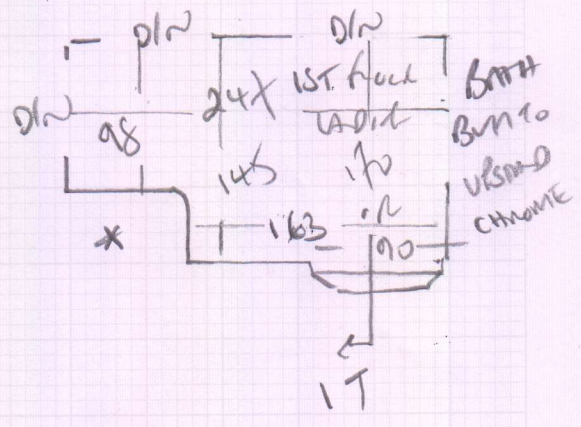
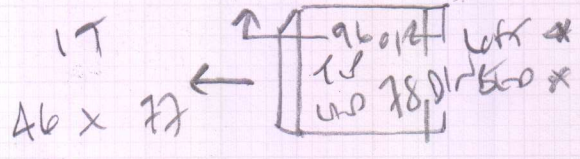

- ↓ 42 x 81
- WT 62 x 92
- W8 75 x 114
- W9 68 x 78
- 81
- 40 x 81
- W10 91 x 110
- D/B/W 50 x 120
- (CAR + BATH)

To Grandfire HALL
 (WOOD FLOOR)