

①

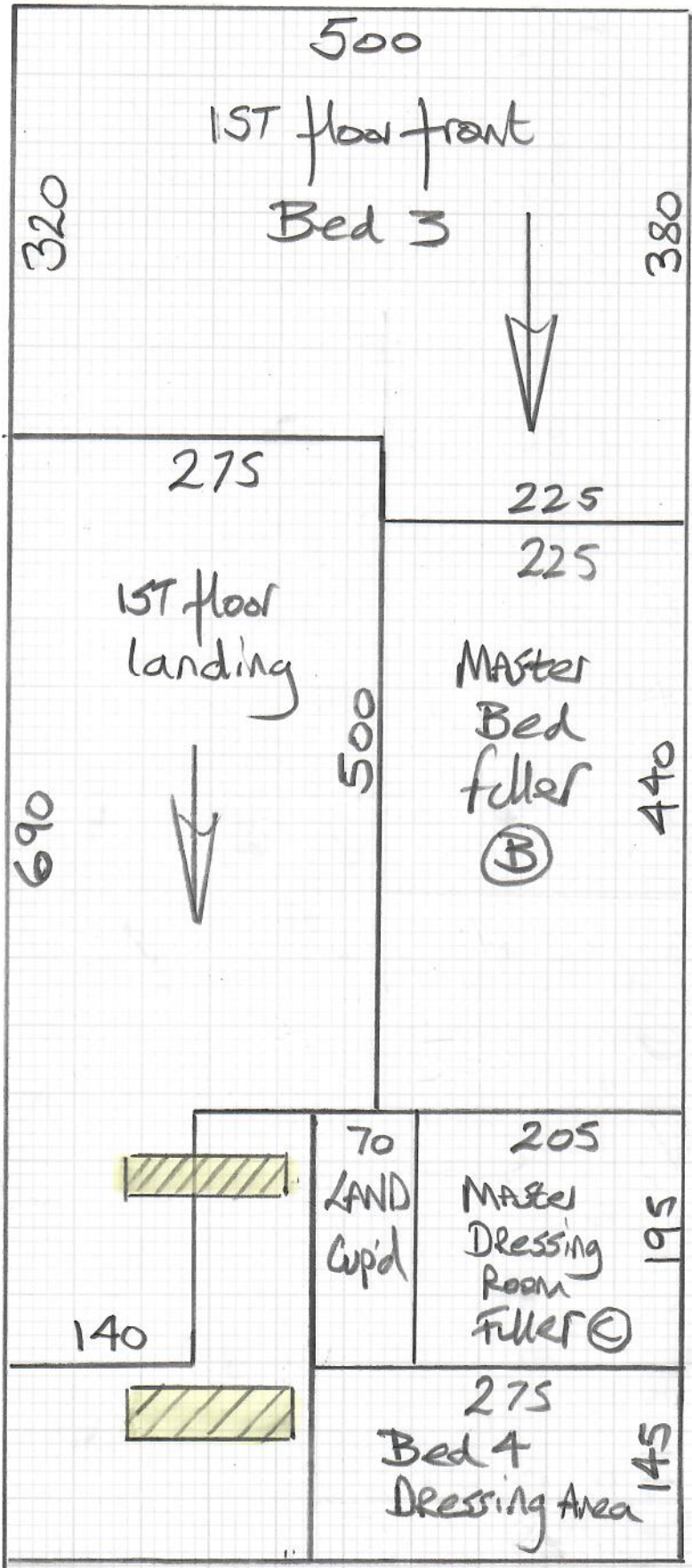

mrcarpet

Job No: R18847  
 Name: Accuro  
 Address:  
 Tel: 1013  
 Sheet: of

YORK  
Col. YOR-232

Cut Plan ① 1160 x 500  
 Cut Plan ② 580 x 500  
 Cut Plan ③ 725 x 500  
2465 x 500  
 = 123.25m<sup>2</sup>

Bed 5/office 365 x 500  
 = 18.25m<sup>2</sup>

Sep cut  
 Total = 141.50m<sup>2</sup>

u/Lay = 115m<sup>2</sup>

Damage =

\* Must stick s/e T/out & fix u/Lay with spray adhesive as u/floor heating is fitted just below the surface T/out

②

140

360

200

mrcarpet

405  
TOP  
LAND

Master Bed  
& Dressing Rm

Filler

③

R18847  
Accwo

Job No:

Name:

Address:

Tel:

Sheet:

of:

2013

Section

Ⓐ

580



Filler  
Ⓒ

175

500

YORK  
Col. York-232

③

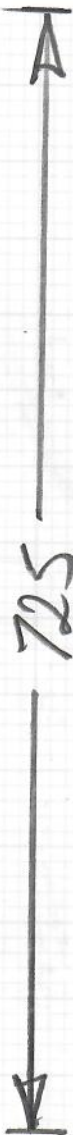
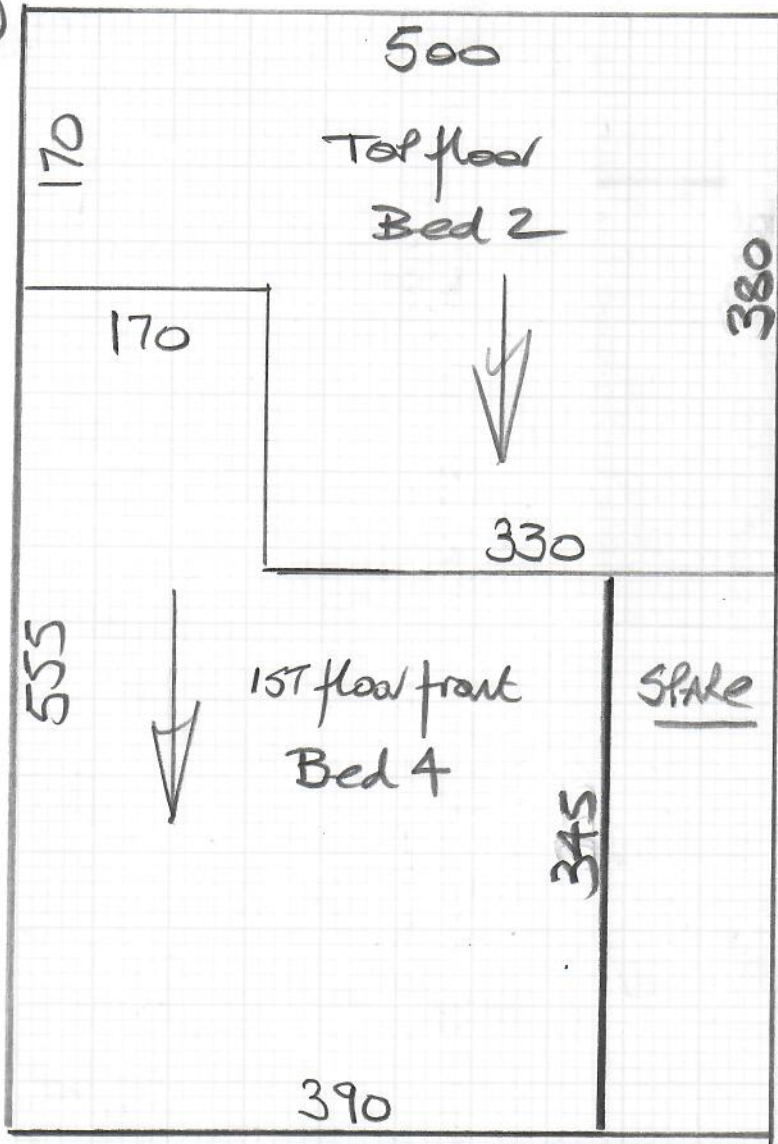

mrcarpet

Job No: R18847

Name: AKURO

Address:

Tel:

Sheet: 3 of 13

YORIK

Col. Yor-232

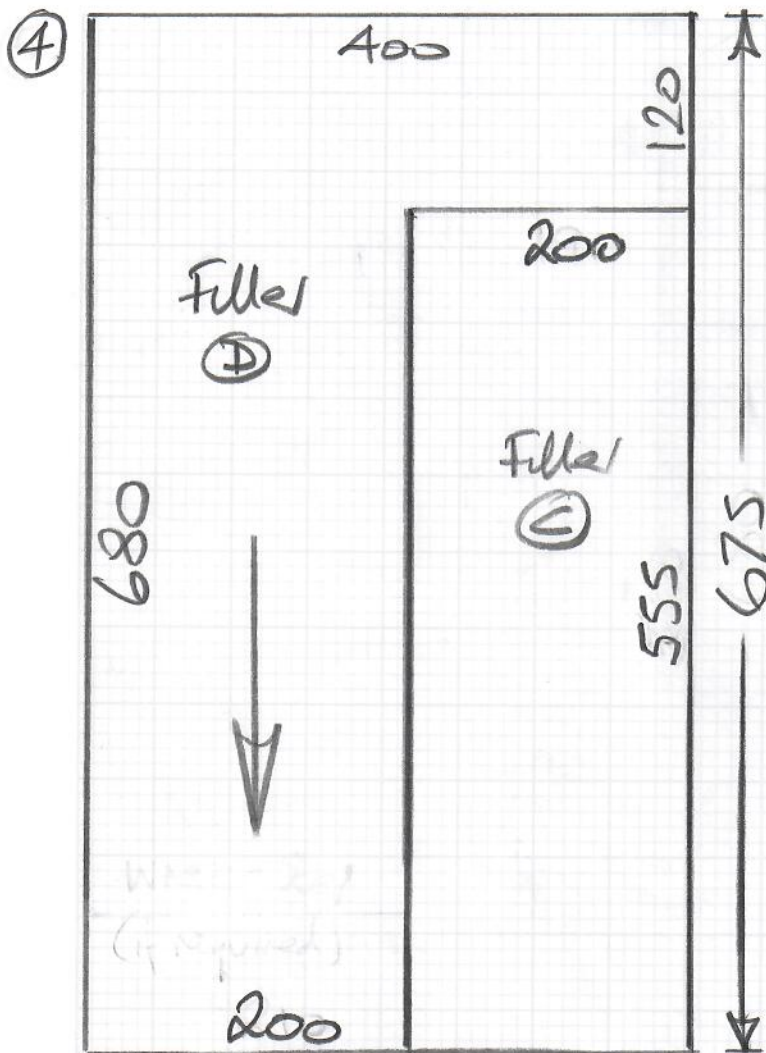

## Basement Leisure Area

Job No: R18847  
Name: Accuro

Address:

④ of 13

Sheet:

York

Col. Yor-220

Section ① 740 x 400

Section ② 555 x 400

Cut Plan ④ 675 x 400

1970 x 400

= 78.80m<sup>2</sup>

v/lay = 72m<sup>2</sup>

Seaming 15Ln

Coir Matting

Col. Natural

Matwell: 115 x 200

= 2.30m<sup>2</sup>

Job No: R18847  
Name: Accuro

Address:  
Tel:  
Sheet: (5 of 13)

Seaming Plan

YORK

Col. YOR-232

BATH



Section (A)

183  
Filler (B)

TOP LAND

Seam Here to be lined up with Centre of Bed

Robes to be built here

Master Bed + Dressing Room (Seaming Plan)

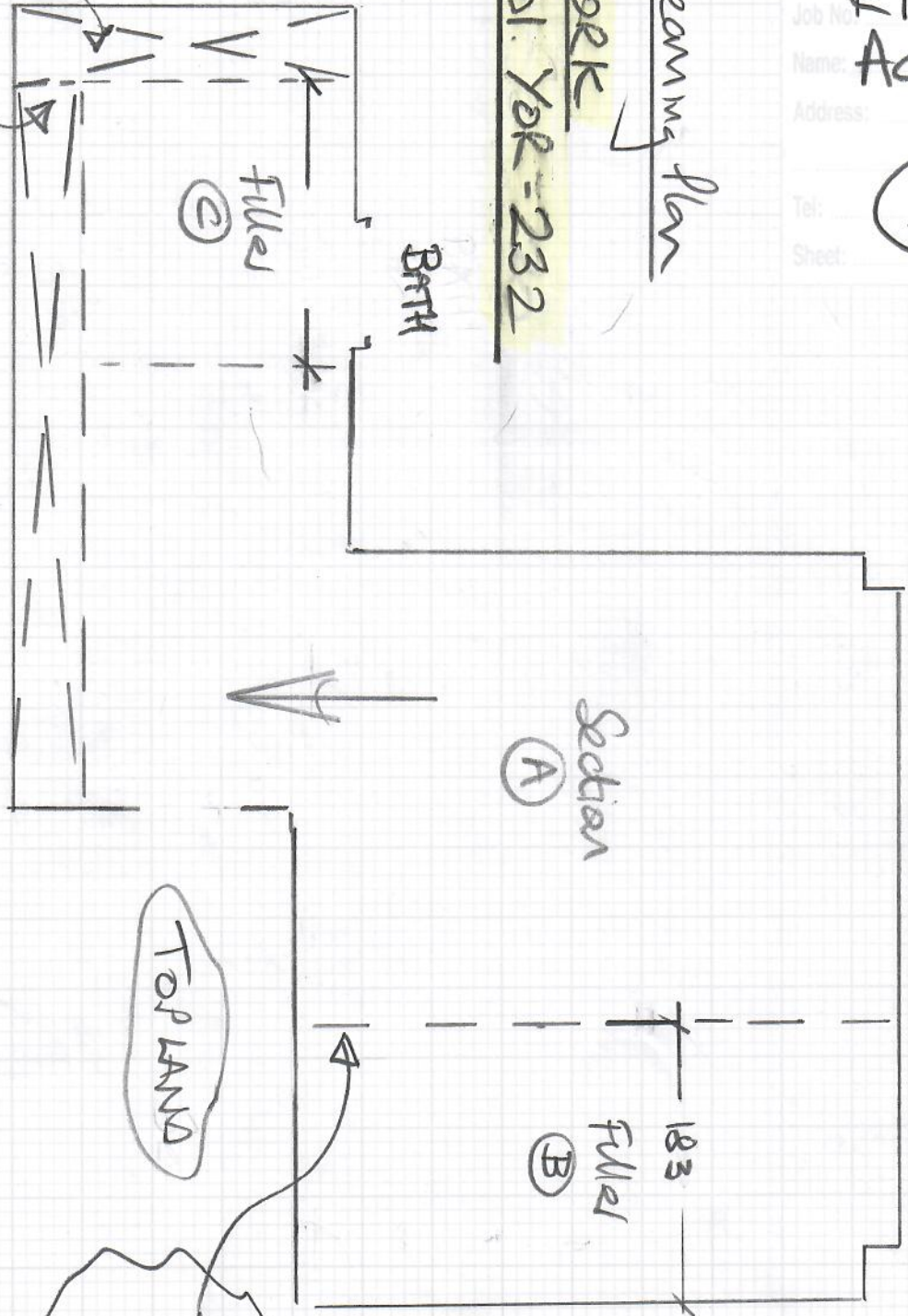

Top floor

R18847  
Accuso

Master Bedroom & Dressing Area

6 of 13

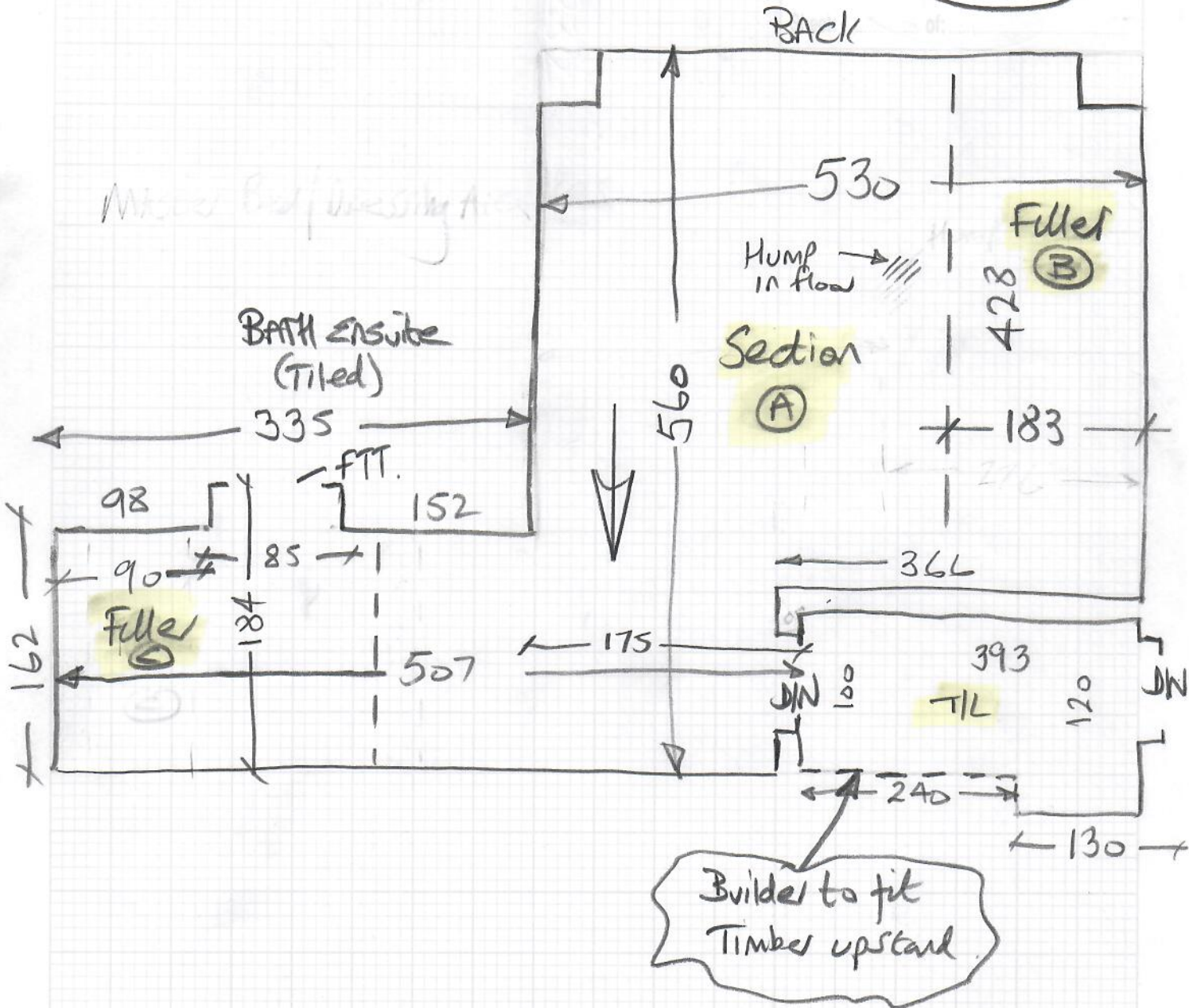

FTT = fit to tiles.

TOP floor

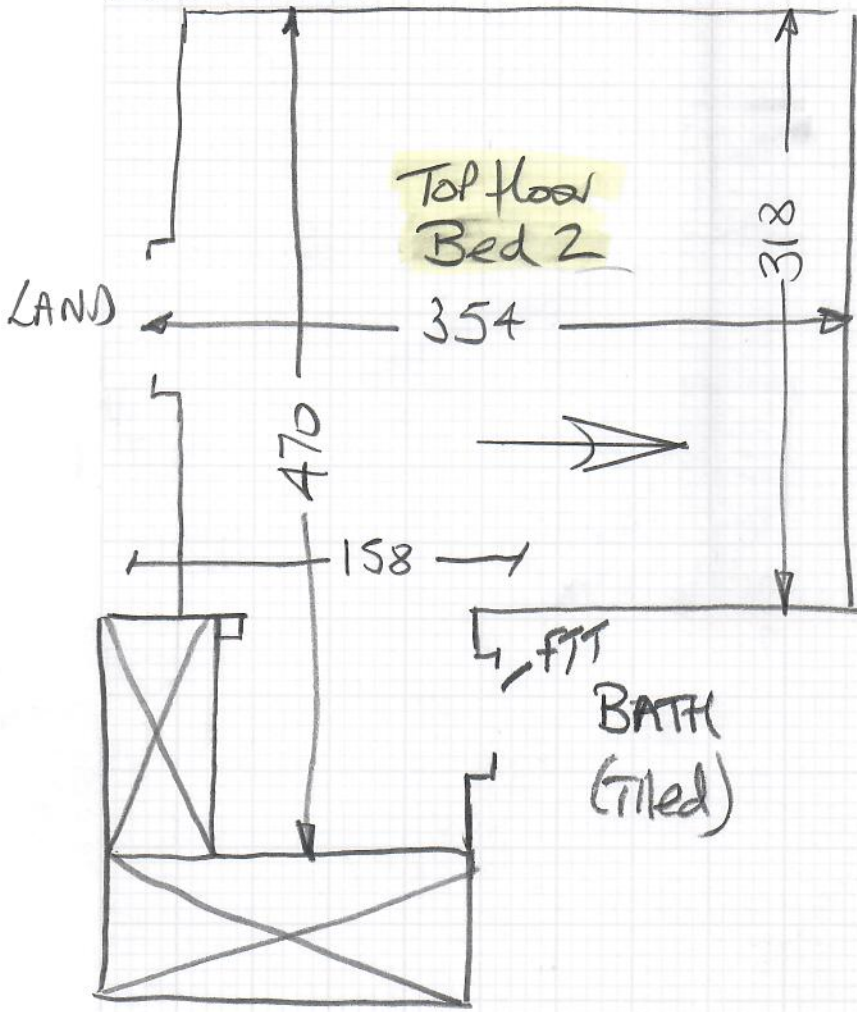

Job No: R18847

Name: Accuro

Address:

Tel:

Sheet:

7 of 13

1ST Floor

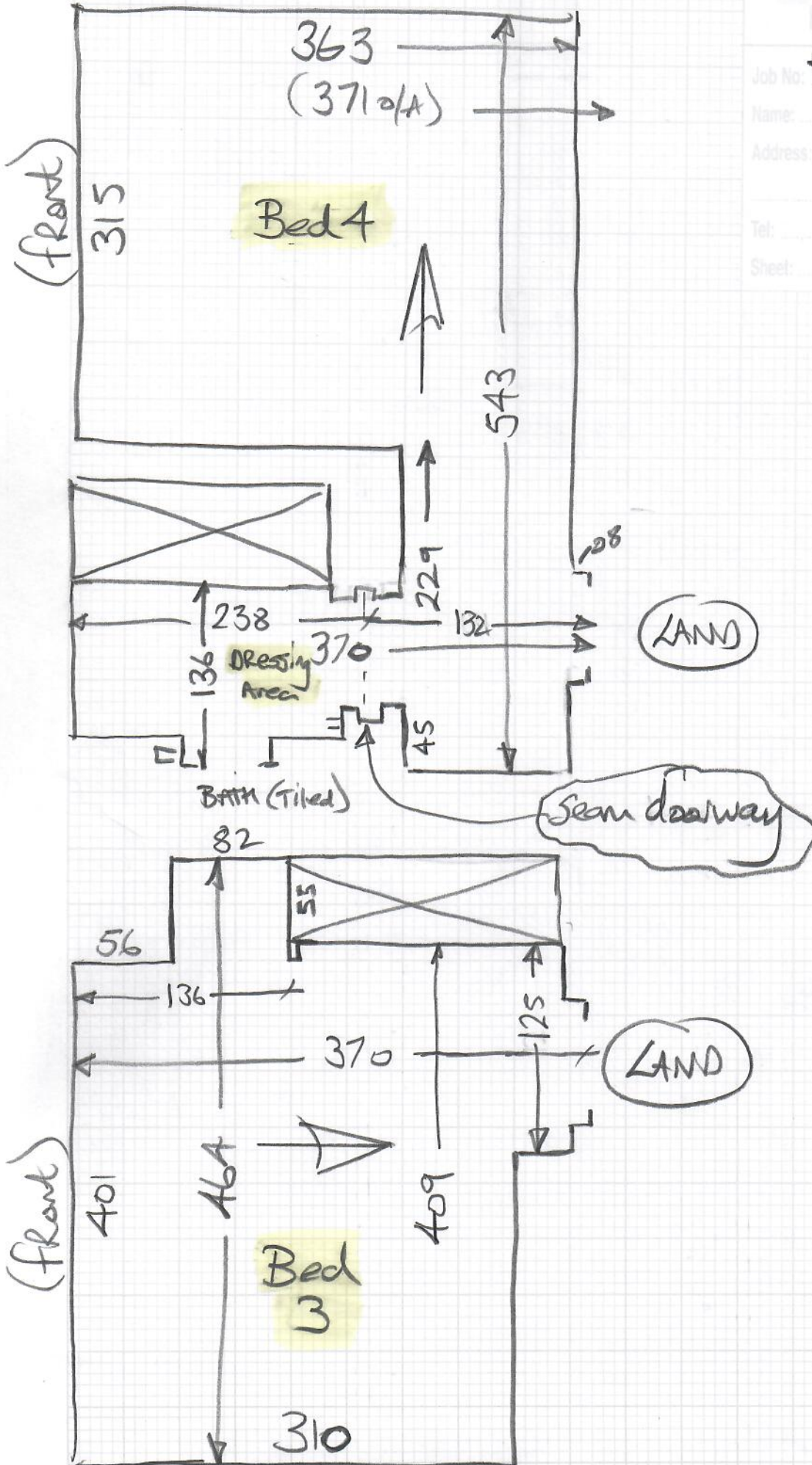

mrcarpet  
 Job No: R18847  
 Name: Accuro  
 Address:  
 Tel:  
 Sheet: of

80 of 13

157 Floor

mrcarpet

Job: R18847  
Name: Accuro  
Address:  
Tel:  
Sheet:

9 of 13

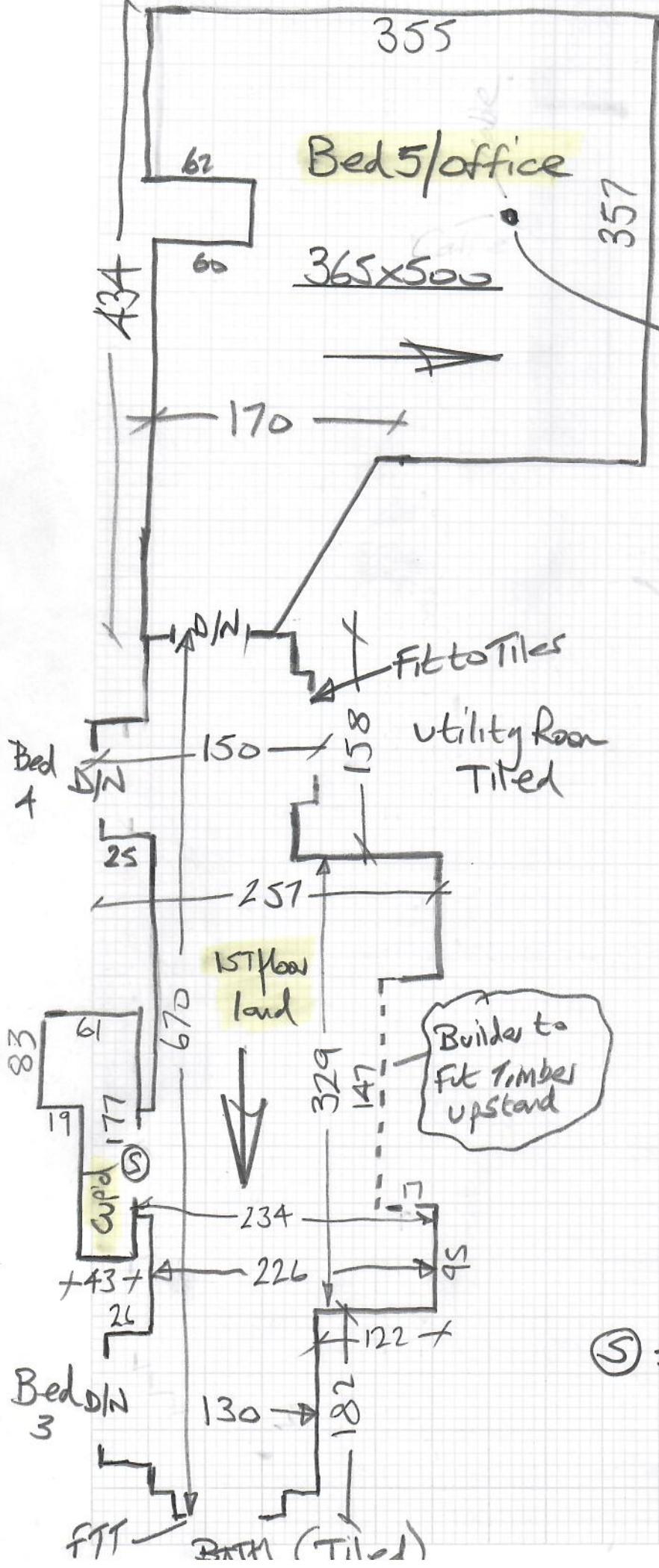

Cut Carpet & Bring Cable through but agree exact location with Site formen beforehand.

Builder to fit timber upstand

Ⓢ = Seam Downway



# Basement Leisure Area

YORK - YOR-220

R18847  
ALCWO

11 of 13

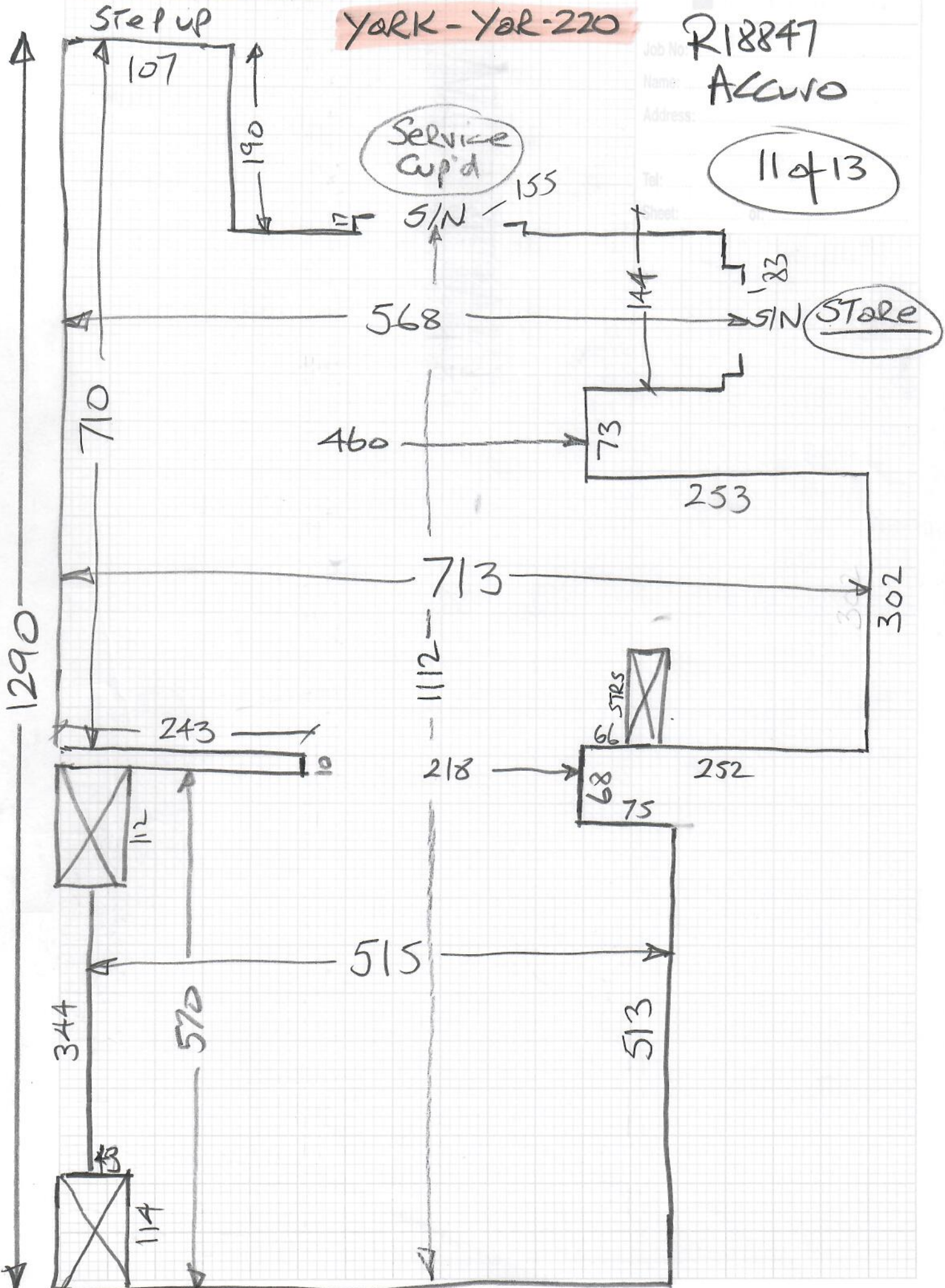

R18847  
Accuro

12 of 13

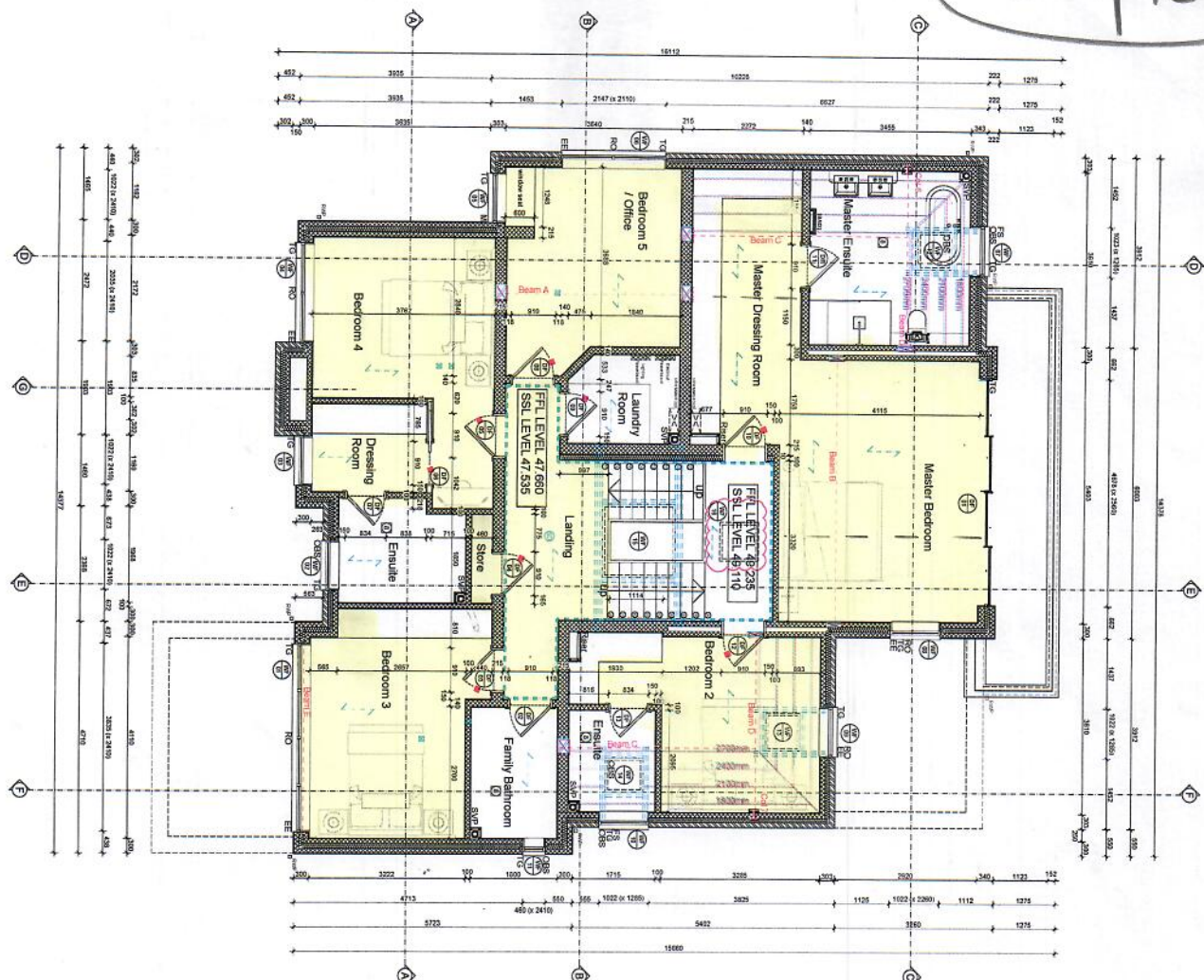

**SYMBOL LEGEND**

TG Details: Tightened clearance to BS5832:1981 and in accordance with approved Document F17.4 (see page 16) (see also page 16) (see also page 16)

M Details: Mastic pointing standard (see page 16)

FS Details: Unit which is fixed or installed to be 'Fixed Shut'

RO Details: Unit which has a raised opening (see page 16)

CSB Details: Castor Castor panel (see page 16)

RMP Details: Raised square aluminium (see page 16)

EE Details: External Emergency Egress (see page 16)

**ELECTRICAL LEGEND**

All electrical work should meet the requirements of Part P Building Regulations 2006 and be installed and tested by a person competent to do so. A certificate of completion (see page 16) (see page 16)

Ⓢ Ceiling mounted extract fan (see page 16)

**WALL TYPES LEGEND**

External Clay Wall: 100mm Brickwork, 100mm Blockwork, 100mm Blockwork

Internal Clay Wall: 100mm Brickwork, 100mm Blockwork, 100mm Blockwork

140mm Blockwork

100mm Blockwork

100mm Blockwork

**KEY TO FIRE SYMBOLS**

FD30: 30 min fire door with intumescent (see page 16) (see page 16)

FD60: 60 min fire door with intumescent (see page 16) (see page 16)

FD90: 90 min fire door with intumescent (see page 16) (see page 16)

FD120: 120 min fire door with intumescent (see page 16) (see page 16)

FD150: 150 min fire door with intumescent (see page 16) (see page 16)

FD180: 180 min fire door with intumescent (see page 16) (see page 16)

FD240: 240 min fire door with intumescent (see page 16) (see page 16)

**KEY TO INT. TPOUL DRAINAGE**

INT. TPOUL DRAINAGE: 100mm (see page 16) (see page 16)

INT. TPOUL DRAINAGE: 150mm (see page 16) (see page 16)

INT. TPOUL DRAINAGE: 200mm (see page 16) (see page 16)

INT. TPOUL DRAINAGE: 250mm (see page 16) (see page 16)

INT. TPOUL DRAINAGE: 300mm (see page 16) (see page 16)

**STARCASE CRITERIA - HOUSES**

BASEMENT TO GROUND FLOOR TOTAL RISE = 3150 mm

NO RISERS @

PITCH OF STARCASE @

OVERALL STRIKES TO BE

GROUND TO NEXT FLOOR TOTAL RISE

NO RISERS @

PITCH OF STARCASE @

OVERALL STRIKES TO BE

HEIGHT TO TOP OF VENTILATING = 3000 mm

MIN 200mm clear headroom above stair path line

No.	Date	Revisions	Drawn
11	04/21	Structural team added	ES
12	05/21	Structural team added	ES
13	06/21	Engineers addition updated	ES
14	06/21	Master En-suite and Bedroom 4 updated	ES
15	06/21	Master En-suite and Bedroom 4 updated	ES
16	06/21	Master En-suite and Bedroom 4 updated	ES
17	06/21	Master En-suite and Bedroom 4 updated	ES
18	06/21	Master En-suite and Bedroom 4 updated	ES
19	06/21	Master En-suite and Bedroom 4 updated	ES

**WATERPROOFING BY SPECIALISTS SPECIFICATIONS**

PLEASE REFER TO RK SIGNATURES DRAWINGS FOR FULL INTERIOR DESIGN DRAWINGS FOR FULL MAKE DESIGN

PLEASE REFER TO M+H ENGINEERS DRAWINGS FOR FULL STRUCTURAL DESIGN

PLEASE NOTE THIS DRAWING IS INTENDED TO BE PRINTED IN COLOUR

**ACCURO RESIDENTIAL**

Site Address: 8 Links Green Way, Cobham, Surrey, KT11 2QH

Description: First Floor Plan

Drawing Number: 21-003-11-003-02

Scale: 1:50 @ A1

Date: Feb-21

Checked: mb

Drawn: ES

Checked: mb

**Bluesky CAD**

Architectural Consultants

FERNERBERGA HOUSE, ALEXANDRA ROAD, HAMPSHIRE ROAD, ANDRINGTON ROAD, NOTTINGHAM, Notts, NG7 2NS

01525 757285

www.blueskycad.co.uk

**CONSTRUCTION**

THIS DRAWING IS THE PROPERTY OF ACCURO RESIDENTIAL AND MUST NOT BE LOANED, COPIED, REPRODUCED OR USED IN ANY MANNER WITHOUT WRITTEN CONSENT

15112, 15228, 15344, 15460, 15576, 15692, 15808, 15924, 16040, 16156, 16272, 16388, 16504, 16620, 16736, 16852, 16968, 17084, 17200, 17316, 17432, 17548, 17664, 17780, 17896, 18012, 18128, 18244, 18360, 18476, 18592, 18708, 18824, 18940, 19056, 19172, 19288, 19404, 19520, 19636, 19752, 19868, 19984, 20100, 20216, 20332, 20448, 20564, 20680, 20796, 20912, 21028, 21144, 21260, 21376, 21492, 21608, 21724, 21840, 21956, 22072, 22188, 22304, 22420, 22536, 22652, 22768, 22884, 23000, 23116, 23232, 23348, 23464, 23580, 23696, 23812, 23928, 24044, 24160, 24276, 24392, 24508, 24624, 24740, 24856, 24972, 25088, 25204, 25320, 25436, 25552, 25668, 25784, 25900, 26016, 26132, 26248, 26364, 26480, 26596, 26712, 26828, 26944, 27060, 27176, 27292, 27408, 27524, 27640, 27756, 27872, 27988, 28104, 28220, 28336, 28452, 28568, 28684, 28800, 28916, 29032, 29148, 29264, 29380, 29496, 29612, 29728, 29844, 29960, 30076, 30192, 30308, 30424, 30540, 30656, 30772, 30888, 31004, 31120, 31236, 31352, 31468, 31584, 31700, 31816, 31932, 32048, 32164, 32280, 32396, 32512, 32628, 32744, 32860, 32976, 33092, 33208, 33324, 33440, 33556, 33672, 33788, 33904, 34020, 34136, 34252, 34368, 34484, 34600, 34716, 34832, 34948, 35064, 35180, 35296, 35412, 35528, 35644, 35760, 35876, 35992, 36108, 36224, 36340, 36456, 36572, 36688, 36804, 36920, 37036, 37152, 37268, 37384, 37500, 37616, 37732, 37848, 37964, 38080, 38196, 38312, 38428, 38544, 38660, 38776, 38892, 39008, 39124, 39240, 39356, 39472, 39588, 39704, 39820, 39936, 40052, 40168, 40284, 40400, 40516, 40632, 40748, 40864, 40980, 41096, 41212, 41328, 41444, 41560, 41676, 41792, 41908, 42024, 42140, 42256, 42372, 42488, 42604, 42720, 42836, 42952, 43068, 43184, 43300, 43416, 43532, 43648, 43764, 43880, 43996, 44112, 44228, 44344, 44460, 44576, 44692, 44808, 44924, 45040, 45156, 45272, 45388, 45504, 45620, 45736, 45852, 45968, 46084, 46200, 46316, 46432, 46548, 46664, 46780, 46896, 47012, 47128, 47244, 47360, 47476, 47592, 47708, 47824, 47940, 48056, 48172, 48288, 48404, 48520, 48636, 48752, 48868, 48984, 49100, 49216, 49332, 49448, 49564, 49680, 49796, 49912, 50028, 50144, 50260, 50376, 50492, 50608, 50724, 50840, 50956, 51072, 51188, 51304, 51420, 51536, 51652, 51768, 51884, 52000, 52116, 52232, 52348, 52464, 52580, 52696, 52812, 52928, 53044, 53160, 53276, 53392, 53508, 53624, 53740, 53856, 53972, 54088, 54204, 54320, 54436, 54552, 54668, 54784, 54900, 55016, 55132, 55248, 55364, 55480, 55596, 55712, 55828, 55944, 56060, 56176, 56292, 56408, 56524, 56640, 56756, 56872, 56988, 57104, 57220, 57336, 57452, 57568, 57684, 57800, 57916, 58032, 58148, 58264, 58380, 58496, 58612, 58728, 58844, 58960, 59076, 59192, 59308, 59424, 59540, 59656, 59772, 59888, 60004, 60120, 60236, 60352, 60468, 60584, 60700, 60816, 60932, 61048, 61164, 61280, 61396, 61512, 61628, 61744, 61860, 61976, 62092, 62208, 62324, 62440, 62556, 62672, 62788, 62904, 63020, 63136, 63252, 63368, 63484, 63600, 63716, 63832, 63948, 64064, 64180, 64296, 64412, 64528, 64644, 64760, 64876, 64992, 65108, 65224, 65340, 65456, 65572, 65688, 65804, 65920, 66036, 66152, 66268, 66384, 66500, 66616, 66732, 66848, 66964, 67080, 67196, 67312, 67428, 67544, 67660, 67776, 67892, 68008, 68124, 68240, 68356, 68472, 68588, 68704, 68820, 68936, 69052, 69168, 69284, 69400, 69516, 69632, 69748, 69864, 69980, 70096, 70212, 70328, 70444, 70560, 70676, 70792, 70908, 71024, 71140, 71256, 71372, 71488, 71604, 71720, 71836, 71952, 72068, 72184, 72300, 72416, 72532, 72648, 72764, 72880, 72996, 73112, 73228, 73344, 73460, 73576, 73692, 73808, 73924, 74040, 74156, 74272, 74388, 74504, 74620, 74736, 74852, 74968, 75084, 75200, 75316, 75432, 75548, 75664, 75780, 75896, 76012, 76128, 76244, 76360, 76476, 76592, 76708, 76824, 76940, 77056, 77172, 77288, 77404, 77520, 77636, 77752, 77868, 77984, 78100, 78216, 78332, 78448, 78564, 78680, 78796, 78912, 79028, 79144, 79260, 79376, 79492, 79608, 79724, 79840, 79956, 80072, 80188, 80304, 80420, 80536, 80652, 80768, 80884, 81000, 81116, 81232, 81348, 81464, 81580, 81696, 81812, 81928, 82044, 82160, 82276, 82392, 82508, 82624, 82740, 82856, 82972, 83088, 83204, 83320, 83436, 83552, 83668, 83784, 83900, 84016, 84132, 84248, 84364, 84480, 84596, 84712, 84828, 84944, 85060, 85176, 85292, 85408, 85524, 85640, 85756, 85872, 85988, 86104, 86220, 86336, 86452, 86568, 86684, 86800, 86916, 87032, 87148, 87264, 87380, 87496, 87612, 87728, 87844, 87960, 88076, 88192, 88308, 88424, 88540, 88656, 88772, 88888, 89004, 89120, 89236, 89352, 89468, 89584, 89700, 89816, 89932, 90048, 90164, 90280, 90396, 90512, 90628, 90744, 90860, 90976, 91092, 91208, 91324, 91440, 91556, 91672, 91788, 91904, 92020, 92136, 92252, 92368, 92484, 92600, 92716, 92832, 92948, 93064, 93180, 93296, 93412, 93528, 93644, 93760, 93876, 93992, 94108, 94224, 94340, 94456, 94572, 94688, 94804, 94920, 95036, 95152, 95268, 95384, 95500, 95616, 95732, 95848, 95964, 96080, 96196, 96312, 96428, 96544, 96660, 96776, 96892, 97008, 97124, 97240, 97356, 97472, 97588, 97704, 97820, 97936, 98052, 98168, 98284, 98400, 98516, 98632, 98748, 98864, 98980, 99096, 99212, 99328, 99444, 99560, 99676, 99792, 99908, 100024, 100140, 100256, 100372, 100488, 100604, 100720, 100836, 100952, 101068, 101184, 101300, 101416, 101532, 101648, 101764, 101880, 101996, 102112, 102228, 102344, 102460, 102576, 102692, 102808, 102924, 103040, 103156, 103272, 103388, 103504, 103620, 103736, 103852, 103968, 104084, 104200, 104316, 104432, 104548, 104664, 104780, 104896, 105012, 105128, 105244, 105360, 105476, 105592, 105708, 105824, 105940, 106056, 106172, 106288, 106404, 106520, 106636, 106752, 106868, 106984, 107100, 107216, 107332, 107448, 107564, 107680, 107796, 107912, 108028, 108144, 108260, 108376, 108492, 108608, 108724, 108840, 108956, 109072, 109188, 109304, 109420, 109536, 109652, 109768, 109884, 110000, 110116, 110232, 110348, 110464, 110580, 110696, 110812, 110928, 111044, 111160, 111276, 111392, 111508, 111624, 111740, 111856, 111972, 112088, 112204, 112320, 112436, 112552, 112668, 112784, 112900, 113016, 113132, 113248, 113364, 113480, 113596, 113712, 113828, 113944, 114060, 114176, 114292, 114408, 114524, 114640, 114756, 114872, 114988, 115104, 115220, 115336, 115452, 115568, 115684, 115800, 115916, 116032, 116148, 116264, 116380, 116496, 116612, 116728, 116844, 116960, 117076, 117192, 117308, 117424, 117540, 117656, 117772, 117888, 118004, 118120, 118236, 118352, 118468, 118584, 118700, 118816, 118932, 119048, 119164, 119280, 119396, 119512, 119628, 119744, 119860, 119976, 120092, 120208, 120324, 120440, 120556, 120672, 120788, 120904, 121020, 121136, 121252, 121368, 121484, 121600, 121716, 121832, 121948, 122064, 122180, 122296, 122412, 122528, 122644, 122760, 122876, 122992, 123108, 123224, 123340, 123456, 123572, 123688, 123804, 123920, 124036, 124152, 124268, 124384, 124500, 124616, 124732, 124848, 124964, 125080, 125196, 125312, 125428, 125544, 125660, 125776, 125892, 126008, 126124, 126240, 126356, 126472, 126588, 126704, 126820, 126936, 127052, 127168, 127284, 127400, 127516, 127632, 127748, 127864, 127980, 128096, 128212, 128328, 128444, 128560, 128676, 128792, 128908, 129024, 129140, 129256, 129372, 129488, 129604, 129720, 129836, 129952, 130068, 130184, 130300, 130416, 130532, 130648, 130764, 130880, 130996, 131112, 131228, 131344, 131460, 131576, 131692, 131808, 131924, 132040, 132156, 132272, 132388, 132504, 132620, 132736, 132852, 132968, 133084, 133200, 133316, 133432, 133548, 133664, 133780, 133896, 134012, 134128, 134244, 134360, 134476, 134592, 134708, 134824, 134940, 135056, 135172, 135288, 135404, 135520, 135636, 135752, 135868, 135984, 136100, 136216, 136332, 136448, 136564, 136680, 136796, 136912, 137028, 137144, 137260, 137376, 137492, 137608, 137724, 137840, 137956, 138072, 138188, 138304, 138420, 138536, 138652, 138768, 138884, 139000, 139116, 139232, 139348, 139464, 139580, 139696, 139812, 139928, 140044, 140160, 140276, 140392, 140508, 140624, 140740, 140856, 140972, 141088, 141204, 141320, 141436, 141552, 141668, 141784, 141900, 142016, 142132, 142248, 142364, 142480, 142596, 142712, 142828, 142944, 143060, 143176, 143292, 143408, 143524, 143640, 143756, 143872, 143988, 144104, 144220, 144336, 144452, 144568, 144684, 144800, 144916, 145032, 145148, 145264, 145380, 145496, 145612, 145728, 145844, 145960, 146076, 146192, 146308, 146424, 146540, 146656, 146772, 146888, 147004, 147120, 147236, 147352, 147468, 147584, 147700, 147816, 147932, 148048, 148164, 148280, 148396, 148512, 148628, 148744, 148860, 148976, 149092, 149208, 149324, 149440, 149556, 149672, 149788, 149904, 150020, 150136, 150252, 150368, 150484, 150600, 150716, 150832, 150948, 151064, 151180, 151296, 151412, 151528, 151644, 151760, 151876, 151992, 152108, 152224, 152340, 152456, 152572, 152688, 152804, 152920, 153036, 153152, 153268, 153384, 153500, 153616, 153732, 153848, 153964, 154080, 154196, 154312, 154428, 154544, 154660, 154776, 154892, 155008, 155124, 155240, 155356, 155472, 155588, 155704, 155820, 155936, 156052, 156168, 156284, 156400, 156516, 156632, 156748, 156864, 156980, 157096, 157212, 157328, 157444, 157560, 157676, 157792, 157908, 158024, 158140, 158256, 158372, 158488, 158604, 158720, 158836, 158952, 159068, 159184, 159300, 159416, 159532, 159648, 159764, 159880, 159996, 160112, 160228, 160344, 160460, 160576, 160692, 160808, 160924, 161040, 161156, 161272, 161388, 161504, 161620, 161736, 161852, 161968, 162084, 162200, 162316, 162432, 162548, 162664, 162780, 162896, 163012, 163128, 163244, 163360, 163476, 163592, 163708, 163824, 163940, 164056, 164172, 164288, 164404, 164520, 164636, 164752, 164868, 164984, 165100, 165216, 165332, 165448, 165564, 165680, 165796, 165912, 166028, 166144, 166260, 166376, 166492, 166608, 166724, 166840, 166956, 167072, 167188, 167304, 167420, 167536, 167652, 167768, 167884, 168000, 168116, 168232, 168348, 168464, 168580, 168696, 168812, 168928, 169044, 169160, 169276, 169392, 169508, 169624, 169740, 169856, 169972, 170088, 170204, 1703

R18847  
 Accuro  
 13 of 13

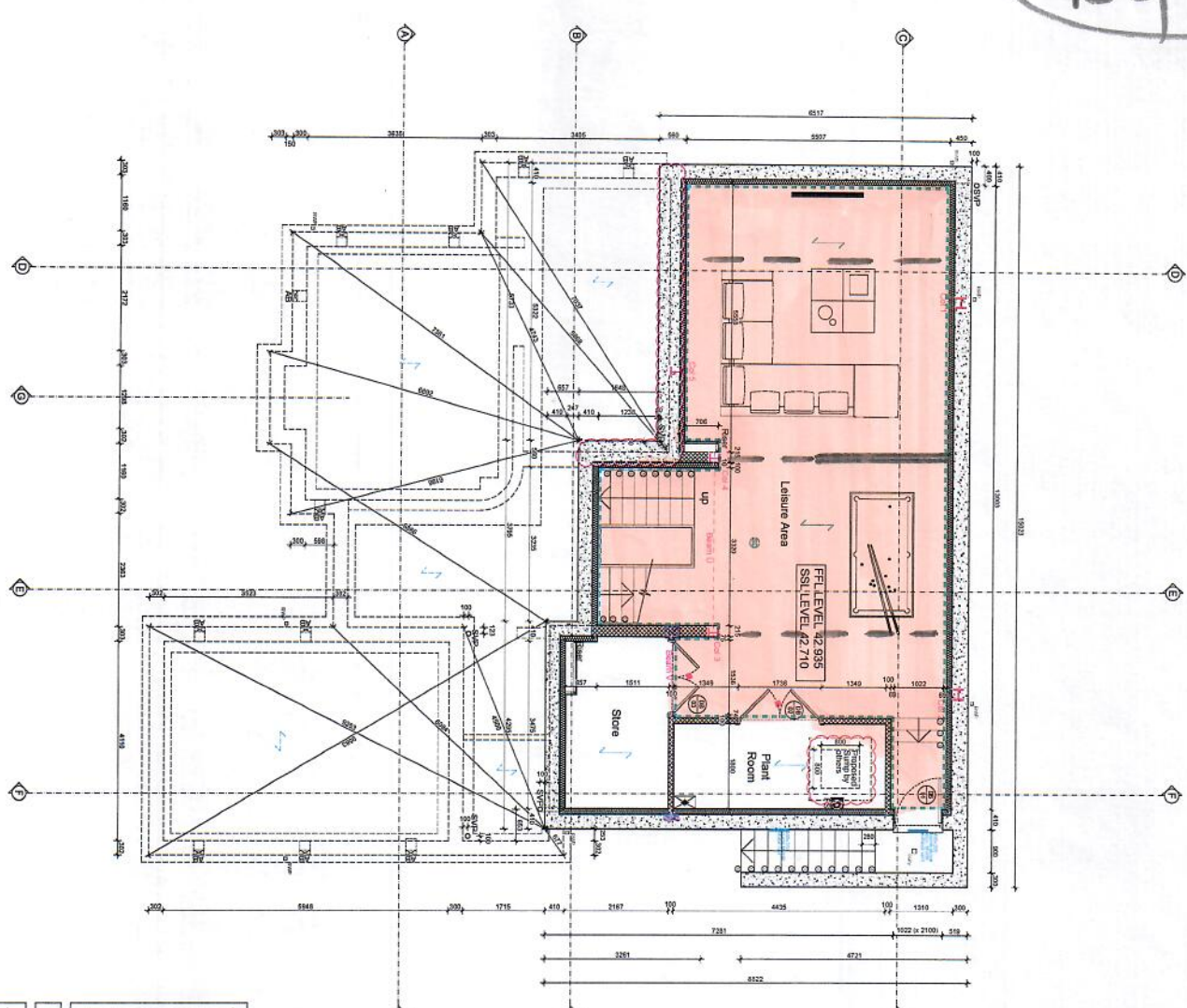

**WALL TYPES LEGEND**  
 All basement strengths are to be confirmed by the contractor. Refer to specification for detailed technical requirements of wall types.  
 Basement Wall: 100mm concrete, 100mm cavity with cavity foam.  
 External Party Wall: 100mm concrete, 100mm cavity with cavity foam.  
 Internal Party Wall: 100mm concrete, 100mm cavity with cavity foam.  
 External Cavity Wall: 100mm concrete, 100mm cavity with cavity foam.  
 Internal Cavity Wall: 100mm concrete, 100mm cavity with cavity foam.  
 External Solid Wall: 100mm concrete, 100mm cavity with cavity foam.  
 Internal Solid Wall: 100mm concrete, 100mm cavity with cavity foam.  
 External Blockwork: 140mm Blockwork.  
 Internal Blockwork: 140mm Blockwork.  
 External Slabwork: 100mm Slabwork.  
 Internal Slabwork: 100mm Slabwork.

**KEY TO FIRE SYMBOLS**  
 FD30 1/2 Hour fire door.  
 FD30 1 Hour fire door.  
 FD30 150 Fire door.  
 FD30 150 Fire door with smoke and heat protection.  
 FD30 150 Fire door with smoke and heat protection and sound insulation.  
 FD30 150 Fire door with smoke and heat protection and sound insulation and fire resistance.  
 FD30 150 Fire door with smoke and heat protection and sound insulation and fire resistance and fire resistance.  
 FD30 150 Fire door with smoke and heat protection and sound insulation and fire resistance and fire resistance and fire resistance.

**KEY TO INT FLOOR DRAINAGE**  
 INT FLOOR DRAINAGE: 100mm diameter, 100mm depth.  
 INT FLOOR DRAINAGE: 100mm diameter, 100mm depth.  
 INT FLOOR DRAINAGE: 100mm diameter, 100mm depth.  
 INT FLOOR DRAINAGE: 100mm diameter, 100mm depth.  
 INT FLOOR DRAINAGE: 100mm diameter, 100mm depth.  
 INT FLOOR DRAINAGE: 100mm diameter, 100mm depth.

**SYMBOL LEGEND**  
 TO: Demos (To be replaced during construction)  
 M: Movable partitions  
 FS: Fixed partitions  
 NO: No door  
 DO: Door  
 SW: Swing  
 CS: Casement  
 DS: Double  
 TR: Timber  
 AL: Aluminium  
 GL: Glass  
 ST: Steel  
 BR: Bronze  
 CH: Chrome  
 SS: Stainless Steel  
 PE: Powder Coated  
 AN: Anodized  
 PA: Painted  
 PO: Polished  
 BR: Brushed  
 SM: Smooth  
 GR: Grained  
 MA: Matt  
 GL: Gloss  
 SA: Satin  
 BR: Bronze  
 CH: Chrome  
 SS: Stainless Steel  
 PE: Powder Coated  
 AN: Anodized  
 PA: Painted  
 PO: Polished  
 BR: Brushed  
 SM: Smooth  
 GR: Grained  
 MA: Matt  
 GL: Gloss  
 SA: Satin

**ELECTRICAL LEGEND**  
 All electrical work should meet the requirements of Part P Building Regulations and be installed, tested and certified by a competent person to a certificate of compliance issued by a competent person (must comply with BS 7671) (Cable tray as shown)

**SUB-STRUCTURE & INCOMING SERVICES**  
 Outline of foundations indicate only. For actual arrangement refer to structural engineer's design & details.  
 For structural design refer to structural engineer's design & details.  
 For foundation design refer to structural engineer's design & details.  
 For foundation design refer to structural engineer's design & details.  
 For foundation design refer to structural engineer's design & details.  
 For foundation design refer to structural engineer's design & details.

THE DRAWING MUST NOT BE CALLED FOR TO THE COMMENCEMENT OF ANY WORK. THE BUILDING IS TO CHECK AND/OR RETIRE. ALL CONSTRUCTION DETAILS TO BE CHECKED AND/OR RETIRED. THE DRAWING IS TO BE USED IN CONJUNCTION WITH ALL OTHER PROJECT DRAWINGS. CONSTRUCTION NOTES AND/OR PROJECT SPECIFICATIONS SHALL BE OBSERVED CAREFULLY.

Rev.	Date	Description	Drawn
1	10/21	External doors updated	ES
2	10/21	Internal doors updated	ES
3	05/21	M&E information added	ES
4	05/21	Engineers information updated	ES
5	07/21	External doors updated	ES
6	07/21	Internal doors updated	ES
7	07/21	Water treatment updated	ES
8	07/21	Water treatment updated	ES

**STAIRCASE CRITERIA - HOUSES**  
 BASEMENT TO GROUND FLOOR TOTAL RISE = 2100 mm  
 NO RISERS @ 175 mm  
 PRICED OR STRACAE @ 175 mm  
 OVERALL STRINGS TO BE 175 mm  
 GROUCH TO FIRST FLOOR TOTAL RISE = 175 mm  
 NO RISERS @ 175 mm  
 PRICED OR STRACAE @ 175 mm  
 OVERALL STRINGS TO BE 175 mm  
 HEIGHT TO TOP OF HANDRAILING = 1020 mm  
 HANDRAILING TO BE 1020 mm  
 HANDRAILING TO BE 1020 mm  
 HANDRAILING TO BE 1020 mm  
 HANDRAILING TO BE 1020 mm  
 HANDRAILING TO BE 1020 mm

**WATERPROOFING BY SPECIALISTS SPECIFICATIONS**  
 PLEASE REFER TO RK SIGNITURES DRAWINGS FOR FULL INTERIOR DESIGN DRAWINGS FOR FULL M&E DESIGN  
 PLEASE REFER TO MHC ENGINEERS DRAWINGS FOR FULL STRUCTURAL DESIGN  
 PLEASE NOTE THIS DRAWING IS INTENDED TO BE PRINTED IN COLOUR

Site Address: 8 Links Green Way, Cobham, Surrey KT11 2QH  
 Description: Basement Floor Plan  
 Drawing Number: 24-003-11-001 T8  
 Scale: 1:50 @ A1  
 Date: Feb 21  
 Drawn: ES  
 Checked: mb

**ACCURO RESIDENTIAL**

**Bluesky CAD**  
 Architectural Consultants  
 FERNBERGA HOUSE  
 AL EXANDA ROAD  
 HAMPSHIRE, GU14 6DG  
 T: 01532 757285  
 WWW.BLUESKYCAD.CO.UK

**TENDER**



308 Worple Road  
Raynes Park  
SW20 8QU  
Tel Nr: 020-8947-7522

## ROLL BREAKDOWN

---

Job No: R18847  
Customer Name: Accuro Residential  
Carpet: York (Hassle Free Supreme Velvet)  
Colour: YOR-232 (Marble Beige)

<b>Roll Size</b>	<b>25.00 x 5.00m</b>
Cut Plan 1	11.60 x 5.00m
Cut Plan 2	5.80 x 5.00m
Cut Plan 3	7.25 x 5.00m
<b>Balance left over</b>	<b>0.35 x 5.00m</b>

**\* Cut the 5.90m & 7.25m off the roll and leave the Roll balance for the 11.50m Cut Plan 1**

---

**\*\* There is also a separate cut of 3.65 x 5.00m for Bed 5 / Office**