

$$W1 = 57 \times 100.$$

$$W2 = 60 \times 105.$$

$$W3 = 60 \times 70.$$

$$9 \times \text{STMS} = 45 \times 73.$$

$$B1 \sim = 45 \times 93.$$

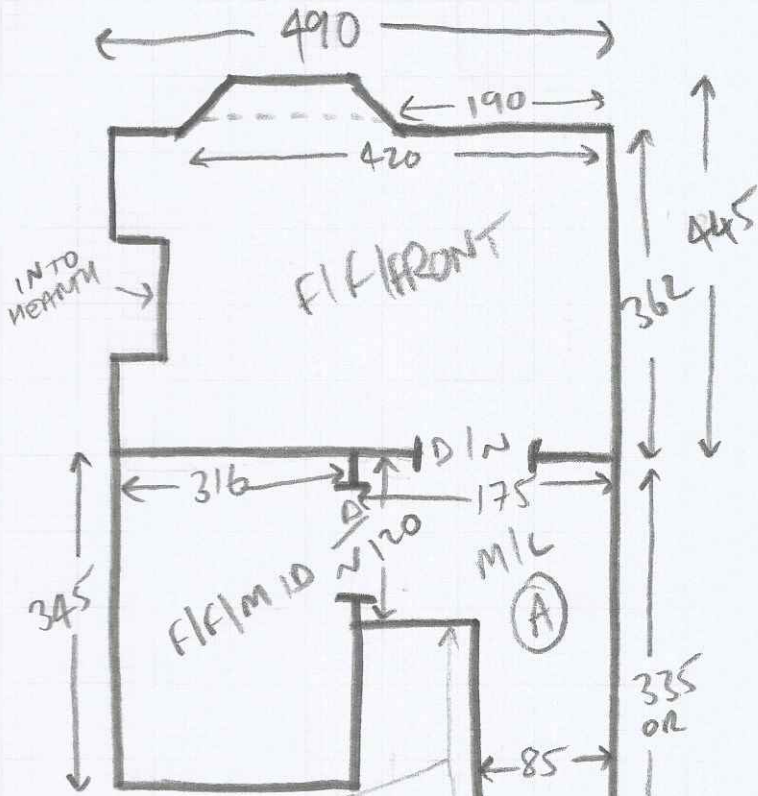

200
CM
SNAP

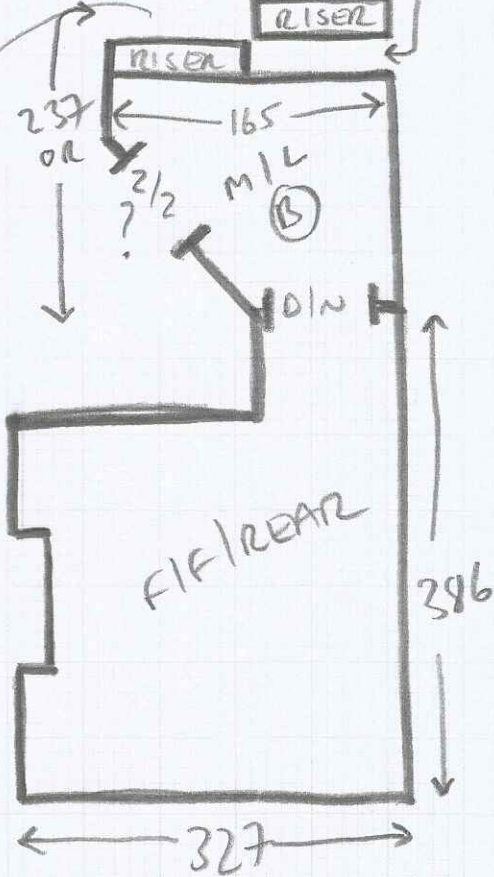

- 11 1/2 STRS = 44 x 76"
- W4 = 53 x 90"
- W5 = 66 x 102"
- W6 = 67 x 121"

AS WINNER 56cm
WIDE
W4-6 NEED
SITE TEMPLATE

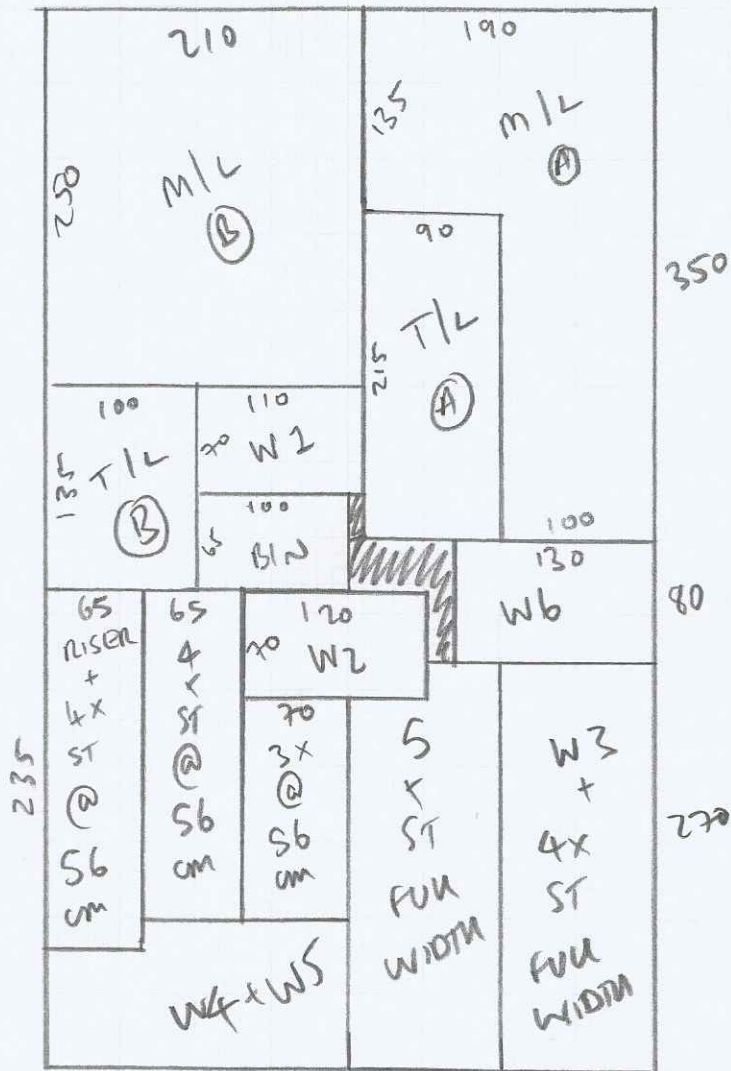

700x400m

LOFT REAR - 290 x 400m
 FIF MID - 3.25 x 4.00m
 FIF REAR - 3.40 x 4.00m
 PLAN - 7.00 x 4.00m

} GIBRALTAR
 113

LOFT FRONT - 4.25 x 5m ← TIGHT
 F/F/F - 4.55 x 5m

} FINE LOOP

Mrs Anais Morniche, 15 Sutherland Gardens

Date of Measure Wed, 7 Oct 20

At 11:30 - 12:00

Floor: Wood / Concrete / other _____

S/edge: Wood/Concrete/No pin/existing (if existing, allow ___ sticks to supplement where necessary)

Sticking Req'd: Yes/No Type: Fastset/Other

Underlay: Re-use Existing / New required

Type: 42oz Felt / Fomalux / PU Foam / Luxury PU Foam / LowTog / Durafit

Doorbars: Alloy / Satin Ali / Polished Ali / Anod / Solid Brass / Chrome / Nisheen Seam/Wood/T/Holds: colour _____

Door Clearance: OK / Low (advise on quote)

Uplift: No / Yes (if "Yes" - what type?) _____

Furniture: No/Yes (if YES, please specify the following) - 1 man / 2 men (Fitter to get paid) £_____ total/per room

Parking Cost: Free / £_____ per hour

Parking Restrictions: (type) / £_____

Congestion Zone: No / Yes

Access: Easy / Hard / 2 men req'd / 2 Floors floor?

Runners: Whipping / Binding (if binding, specify type)

Tape size: 1 1/2" / 2" / 3" / 5"

Style: Top taping / Side-binding

Stairrods: Type _____ Nr _____ Size _____

Must Read: call her on arrival