

Job No: S35354

Name: [unclear]

Address:

Tel:

Sheet: 1/3

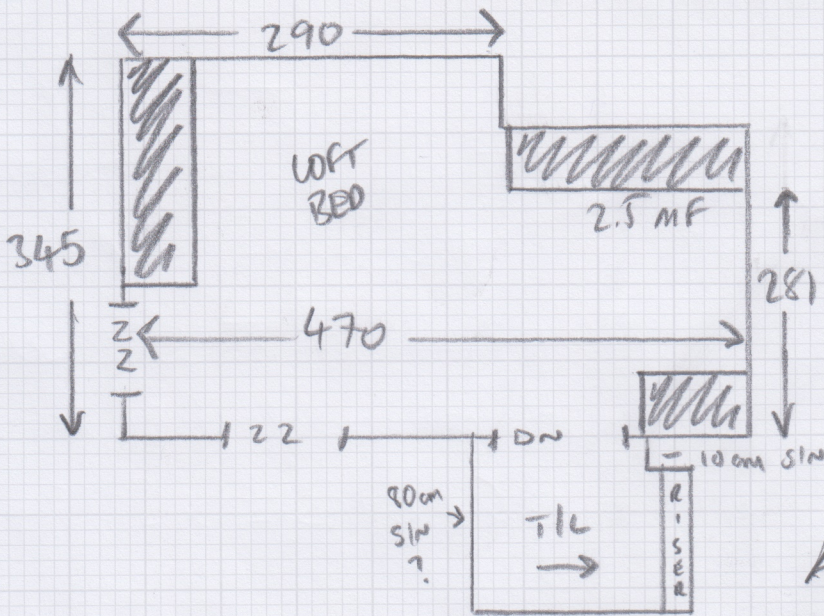

ADAMS
FINE WORCESTER
TWIST.

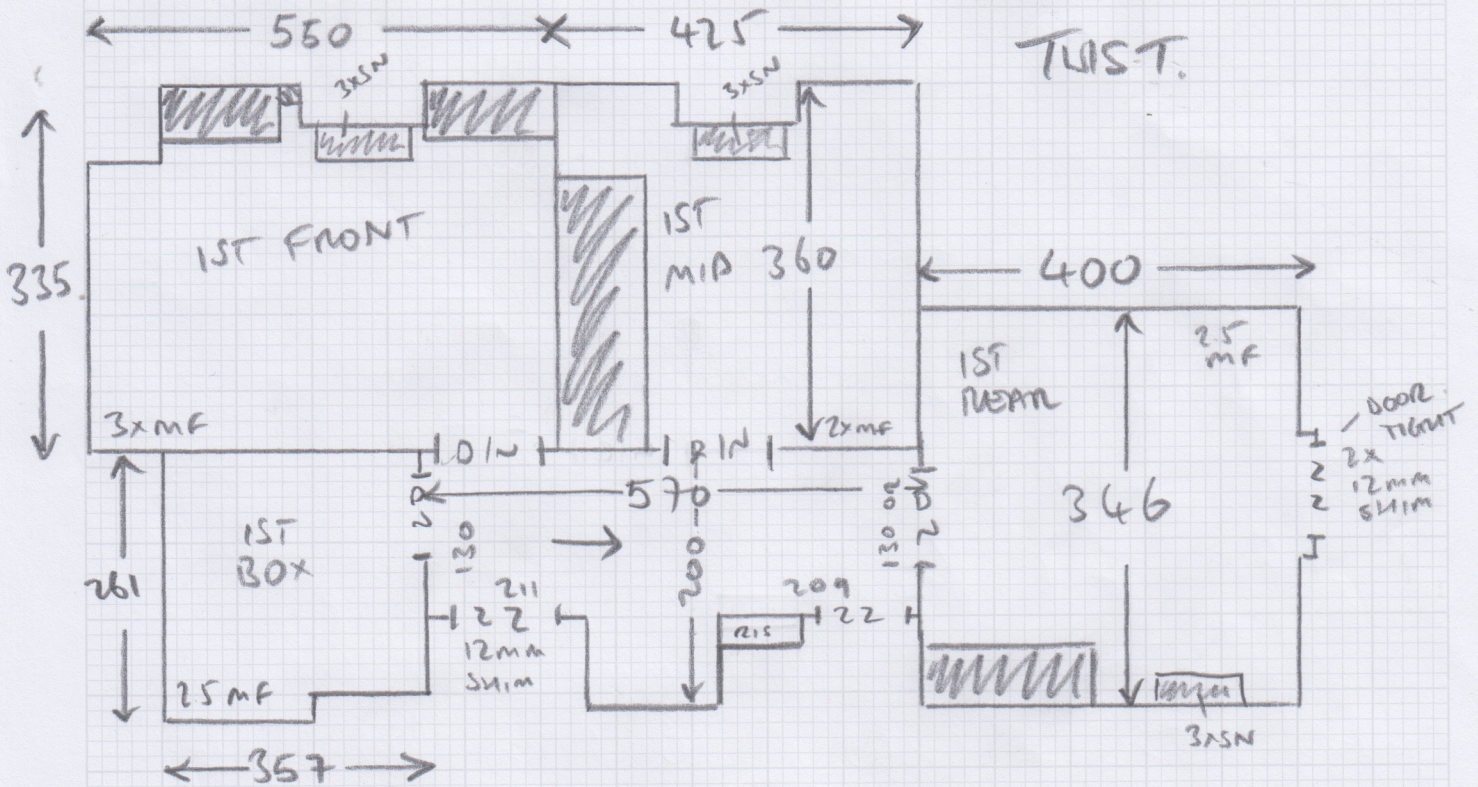

- ✓ TIL = 1000L x 113
- ✓ 2xST = 45 x 86
- ✓ W1 = 85 x 123
- ✓ W2 = 110 x 85
- ✓ 3xST = 45 x 87
- ✓ W3 = 68 x 104
- ✓ W4 = 80 x 127
- ✓ W5 = 75 x 85
- ✓ 1xST = 45 x 87
- ✓ W6 = 69 x 87

- ✓ W7 = 82 x 124
- ✓ W8 = 74 x 82
- ✓ BIN = 45 x 115
- MIL = SEE PLAN
- ✓ 4xST = 45 x 86
- ✓ W9 = 66 x 104
- ✓ W10 = 75 x 122
- ✓ W11 = 70 x 86
- ✓ 5xST = 45 x 86

- ✓ W12 = 67 x 103
- ✓ W13 = 76 x 120
- ✓ W14 = 73 x 86
- ✓ 1xST = 45 x 88
- ✓ BIN2 = 90 x 250
- ↓ TO GROUND FLOOR ↓
- 64 x 29 cm TAPED
- RUB for CVST

Job No: 535354

Name: _____

Address: _____

Tel: _____

Sheet: 2/3

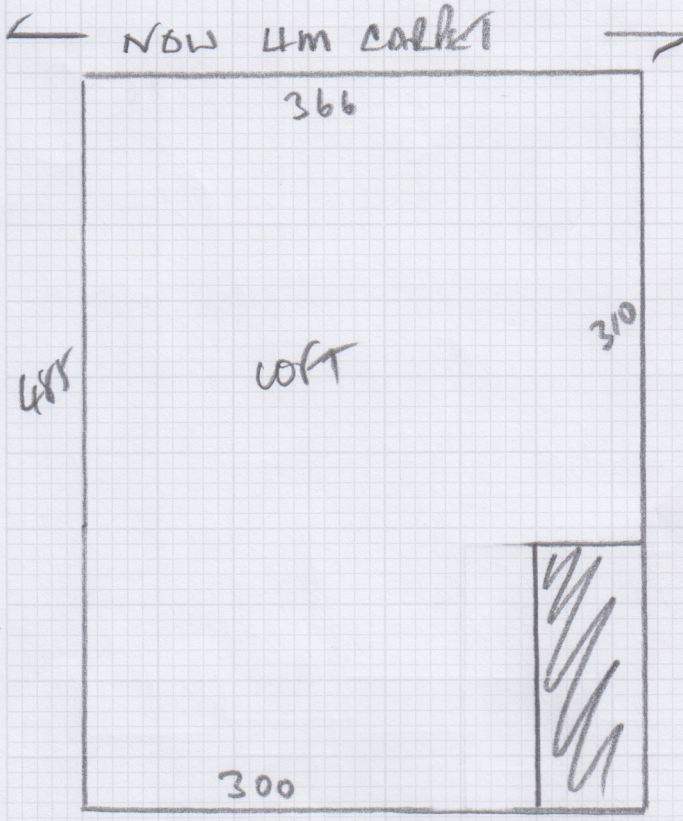

- 410 x 4.00 - 1ST REAR
- ← 485 x 4.00 - LOFT
- 560 x 4.00 - 1ST FRONT
- 370 x 5.00 - 1ST MID
- 730 x 5.00 - WT A
- 370 x 5.00 - WT B

(A)

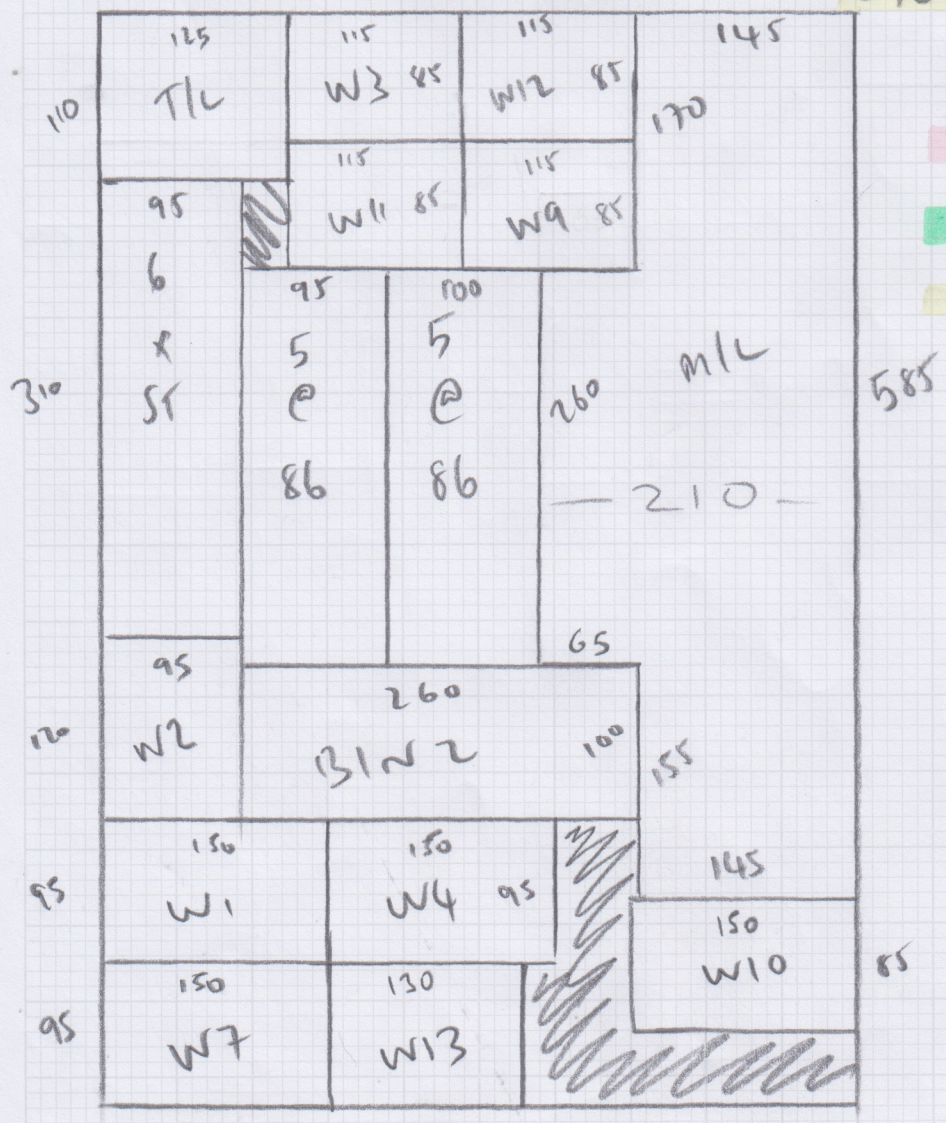

- 14.55 x 4m
- 2.70 x 5m
- 11.00 x 5m

③

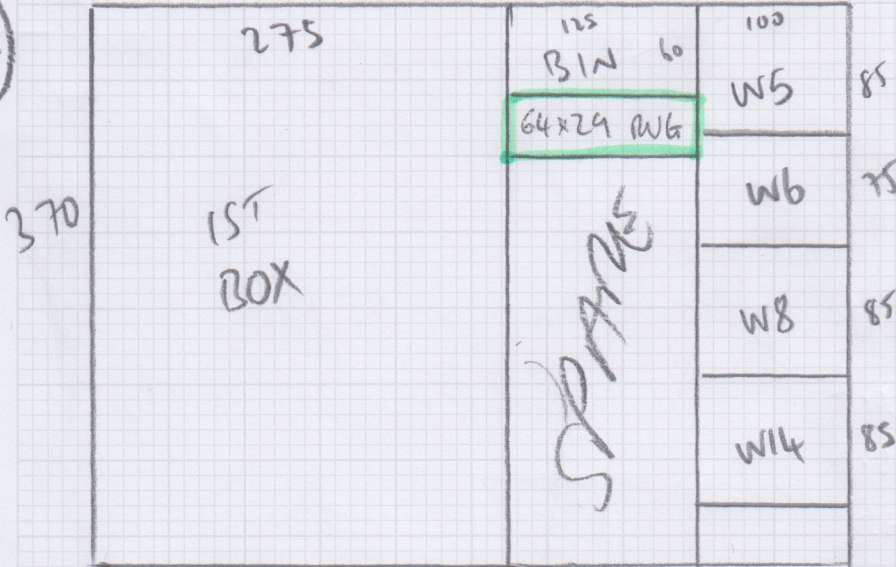

Job No: J35354

Name: _____

Address: _____

Tel: _____

Sheet: 3/3